

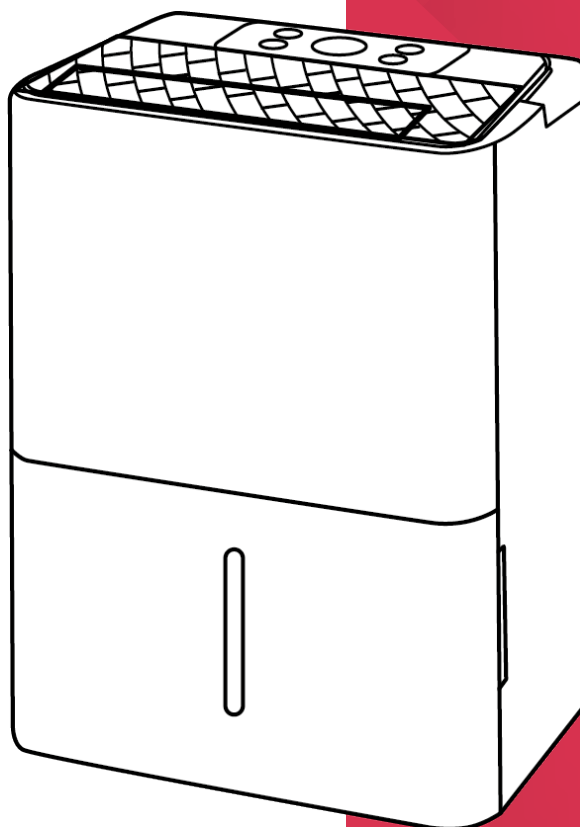

INSTRUCTION MANUAL



12L Dehumidifier | 12L Dehumidifier w/ Purifier

Models: DC12DE & DC12DEPUR

For domestic household use
only.



IMPORTANT

THESE INSTRUCTIONS SHOULD BE READ CAREFULLY AND RETAINED FOR FUTURE REFERENCE. **Note also the information presented on the appliance**

DETAILS OF TYPE AND RATING OF FUSES : T; 3.15A; 250VAC.

CAUTION: FAILURE TO FOLLOW THESE INSTRUCTIONS MAY CAUSE INJURY AND/OR DAMAGE AND MAY INVALIDATE YOUR WARRANTY

Please read the operating instructions carefully before using your dehumidifier for the first time and keep them in a safe place.

WARNING - This appliance must not be used in a bathroom.

WARNING - Do not use this appliance in the immediate surroundings of a bath, a shower or a swimming pool.

- This appliance is not intended for use by persons (including children) with reduced physical, sensory or mental capabilities, or lack of experience and knowledge, unless they have been given supervision or instruction concerning use of the appliance by a person responsible for their safety.
- Children should be supervised to ensure they do not play with the appliance.
- If the supply cord is damaged, it must be replaced by the manufacturer, its service agent or similarly qualified persons in order to avoid a hazard.
- Never immerse the appliance in water or other liquids.
- Operate this unit only on a firm, flat surface to avoid the risk of water leakage. Ensure that the unit is kept upright at all times (including during transport and storage). If it is overturned at any stage it should be left standing upright for 24 hours before use.
- Do not place on soft, unstable or non-horizontal/angled surfaces.
- Never operate the appliance if a cable or connector has been damaged, after appliance malfunction or if the appliance was dropped or is otherwise damaged.
- Please ask a professional service agent to repair the product. Improper repair may cause danger to users.
- Disconnect the appliance from mains power whenever it is not in use, before relocating it, and before cleaning.
- Operate the appliance only at the voltage specified on the rating label.
- Only connect the unit to a properly installed and easily accessible socket so that you can quickly disconnect the plug if necessary.
- Do not connect this product to the mains using an extension lead.
- Do not connect the dehumidifier to a multiple socket outlet, which is also being used for other electrical appliances
- This dehumidifier is only intended for **INDOOR RESIDENTIAL** applications. This dehumidifier should not be used for commercial or industrial or leisure applications or in small enclosed spaces.
- Never use the mains lead as a carrying strap or pulling lead.
- To avoid a fire or electrocution hazard, **NEVER** put the cord near heat registers, radiator, stoves or heaters.
- **DO NOT** cover cord with carpeting, throw rugs, runners, or similar coverings.
- **DO NOT** route cord under furniture or appliances. Take care to position the cord away

from traffic areas and where it will not be a tripping hazard.

- **DO NOT COVER.** Never cover or obstruct in any way the outlet at the top of the dehumidifier or the air inlet slots at the rear of the dehumidifier.
- Only operate this appliance with a minimum of 50cm clearance all around i.e. away from walls, furniture and overhanging objects such as curtains or a shelf.
- To prevent spillage, empty the water tank before lifting or relocating the appliance.
- Do not tip the appliance to any side as escaping water could damage the appliance.
- **WARNING:** Never leave water in the reservoir when the appliance is not in use, microorganisms can grow in stagnant water, the water tank should be emptied and cleaned regularly and properly. Empty the tank, clean and dry it when not in use and before putting into storage.
- **CAUTION:** Clean and empty the water tank at least every third day. Empty the water tank and clean it with fresh tap water or mild detergent. Remove any scale, deposits, or film that has formed on the sides of the water tank or on interior surfaces using soft non-abrasive cleaning agents (such as washing up liquid), wipe all surfaces dry on completion.
- **WARNING** – The water collected in the tank is must never be used for drinking, it is not suitable for human, bird or animal consumption.
- Be aware that high humidity levels may encourage the growth of biological organisms in the environment.
- Monitor the area around the dehumidifier to ensure there is no damp or wet. Do not allow absorbent materials, such as carpeting, drapes, or tablecloths to become damp.
- Air inlet filter must be cleaned regularly to ensure correct operation and to avoid damage to the appliance.
- Never operate the product without the filter
- **WARNING:** To avoid danger of suffocation please remove all packaging materials particularly plastic and EPS and keep these away from vulnerable people, children and babies.
- **IMPORTANT:** Do not use this unit where the ambient temperature is lower than 5°C, otherwise the evaporating coil will ice up heavily and this will affect the performance of the product and potentially cause a malfunction.
- **NEVER** drop or insert any object into any openings.
- Do not use the appliance in locations where paint, petrol or other flammable liquids are used or stored.
- Do not use bug sprays or other flammable cleansers/vapour sprays on or around the unit.
- Always switch off the unit and take the plug out of the socket:
 - If you are not using the unit
 - Before you clean or carry out maintenance on the unit
 - If a fault occurs
 - In the event of an electrical storm.



WARNING: For using R290 refrigerant. This symbol shows that this appliance uses a flammable refrigerant. If the refrigerant is leaked and exposed to an external ignition source, there is a risk of fire.

CAUTION: RISK OF FIRE/FLAMMABLE MATERIALS. THE APPLIANCE MUST BE INSTALLED, USED & STORED IN AN AREA THAT IS GREATER THAN 4m².



NB: These symbols on your device mean:

- This appliance is filled with Propane gas R290. Follow strictly the manufacturer's instruction concerning use and repairs!
- It is hazardous for anyone other than an Authorised Service Person to service this appliance. In Queensland - the authorised Service Person **MUST** hold a Gas Work Authorisation for hydrocarbon refrigerants to carry out servicing or repairs where the gas system is being opened or charged.
- Before using this appliance, you must carefully read the entire instruction manual.
- Do not install, operate or store the device in a room with a floor area smaller than 4m².
- Repairs must be performed based on the recommendations from the manufacturing company.
- Note also the information presented on the appliance.
- Do not use means to accelerate the defrosting process or to clean, other than those recommended by the manufacturer.
- The appliance shall **NOT** be stored in a room with continuously operating ignition sources (for example: open flames, an operating gas appliance or an operating electric heater).
- Do not pierce or burn.
- Be aware that the refrigerants may not contain an odour.
- The appliance should be installed, operated and stored in a room with a floor area according to the amount of refrigerant to be charged. For specific information on the type of gas and the amount, please refer to the relevant label on the unit itself. When there are differences between the label and the manual on the Min. room area description, the description on label shall prevail.
- Compliance with national gas regulations shall be observed.
- Keep ventilation openings clear of obstruction.
- The appliance shall be stored so as to prevent mechanical damage from occurring.
- A warning that the appliance shall be stored in a well-ventilated area where the room size corresponds to the room area as specified for operation.
- Any person who is involved with working on or breaking into a refrigerant circuit should hold a current valid certificate from an industry-accredited assessment authority, which authorises their competence to handle refrigerants safely in accordance with an industry recognised assessment specification.
- Servicing shall only be performed as recommended by the equipment manufacturer. Maintenance and repair requiring the assistance of other skilled personnel shall be carried out under the supervision of the person competent in the use of flammable refrigerants.

1. Transport of equipment containing flammable refrigerants - see transport regulations
2. Marking of equipment using signs - see local regulations
3. Disposal of equipment using flammable refrigerants - see national regulations.
4. Storage of equipment/appliances - The storage of equipment should be in accordance with the manufacturer's instructions.
5. Storage of packed (unsold) equipment - storage package protection should be constructed such that mechanical damage to the equipment inside the package will not cause a leak of the refrigerant charge. The maximum number of pieces of equipment permitted to be stored together will be determined by local regulations.
6. Information on servicing
 - **Checks to the area**

Prior to beginning work on systems containing flammable refrigerants, safety checks are necessary to ensure that the risk of ignition is minimised. For repair to the refrigerating system, the following precautions shall be complied with prior to conducting work on the system.
 - **Work procedure**

Work shall be undertaken under a controlled procedure so as to minimise the risk of a flammable gas or vapour being present while the work is being performed.
 - **General work area**

All maintenance staff and others working in the local area shall be instructed on the nature of work being carried out. Work in confined spaces shall be avoided. The area around the workspace shall be sectioned off. Ensure that the conditions within the area have been made safe by control of flammable material.
 - **Checking for presence of refrigerant**

The area shall be checked with an appropriate refrigerant detector prior to and during work, to ensure the technician is aware of potentially flammable atmospheres. Ensure that the leak detection equipment being used is suitable for use with flammable refrigerants, i.e. non-sparking, adequately sealed or intrinsically safe.
 - **Presence of fire extinguisher**

If any hot work is to be conducted on the refrigeration equipment or any associated parts, appropriate fire extinguishing equipment shall be available to hand. Have a dry powder or CO₂ fire extinguisher adjacent to the charging area.
 - **No ignition sources**

No person carrying out work in relation to a refrigeration system which involves exposing any pipe work that contains or has contained flammable refrigerant shall use any sources of ignition in such a manner that it may lead to the risk of fire or explosion. All possible ignition sources, including cigarette smoking, should be kept sufficiently far away from the site of installation, repairing, removing and disposal, during which flammable refrigerant can possibly be released to the surrounding space. Prior to work taking place, the area around the equipment is to be surveyed to make sure that there are no flammable hazards or ignition risks. No Smoking signs shall be displayed.
 - **Ventilated area**

Ensure that the area is in the open or that it is adequately ventilated before breaking into the system or conducting any hot work. A degree of ventilation shall continue during the period that the work is carried out. The ventilation should safely disperse any released refrigerant and preferably expel it externally into the atmosphere.

- **Checks to the refrigeration equipment**

Where electrical components are being changed, they shall be fit for the purpose and to the correct specification. At all times the manufacturer's maintenance and service guidelines shall be followed. If in doubt consult the manufacturer's technical department for assistance. The following checks shall be applied to installations using flammable refrigerants:

The charge size is in accordance with the room size within which the refrigerant containing parts are installed;

The ventilation machinery and outlets are operating adequately and are not obstructed;

If an indirect refrigerating circuit is being used, the secondary circuit shall be checked for the presence of refrigerant; Marking to the equipment continues to be visible and legible. Markings and signs that are illegible shall be corrected; Refrigeration pipe or components are installed in a position where they are unlikely to be exposed

to any substance which may corrode refrigerant containing components, unless the components are constructed of materials which are inherently resistant to being corroded or are suitably protected against being so corroded.

- **Checks to electrical devices**

Repair and maintenance to electrical components shall include initial safety checks and component inspection procedures. If a fault exists that could compromise safety, then no electrical supply shall be connected to the circuit until it is satisfactorily dealt with. If the fault cannot be corrected immediately but it is necessary to continue operation, an adequate temporary solution shall be used. This shall be reported to the owner of the equipment so all parties are advised.

Initial safety checks shall include:

That capacitors are discharged: this shall be done in a safe manner to avoid possibility of sparking; That there no live electrical components and wiring are exposed while charging, recovering or purging the system; That there is continuity of earth bonding.

- **Repairs to sealed components**

- During repairs to sealed components, all electrical supplies shall be disconnected from the equipment being worked upon prior to any removal of sealed covers, etc. If it is absolutely necessary to have an electrical supply to equipment during servicing, then a permanently operating form of leak detection shall be located at the most critical point to warn of a potentially hazardous situation.
- Particular attention shall be paid to the following to ensure that by working on electrical components, the casing is not altered in such a way that the level of protection is affected. This shall include damage to cables, excessive number of connections, terminals not made to original specification, damage to seals, incorrect fitting of glands, etc. Ensure that apparatus is mounted securely. Ensure that seals or sealing materials have not degraded such that they no longer serve the purpose of preventing the ingress of flammable atmospheres. Replacement parts shall be in accordance with the manufacturer's specifications.

NOTE: The use of silicon sealant may inhibit the effectiveness of some types of leak detection equipment. Intrinsically safe components do not have to be isolated prior to working on them.

- **Repair to intrinsically safe components**

Do not apply any permanent inductive or capacitance loads to the circuit without ensuring that this will not exceed the permissible voltage and current permitted for the equipment in use. Intrinsically safe components are the only types that can be worked on while live in the presence of a flammable atmosphere. The test apparatus shall be at the correct rating. Replace components only with parts specified by the manufacturer. Other parts may result in the ignition of refrigerant in the atmosphere from a leak.

- **Cabling**

Check that cabling will not be subject to wear, corrosion, excessive pressure, vibration, sharp edges or any other adverse environmental effects. The check shall also take into account the effects of aging or continual vibration from sources such as compressors or fans.

- **Detection of flammable refrigerants**

Under no circumstances shall potential sources of ignition be used in the searching for or detection of refrigerant leaks. A halide torch (or any other detector using a naked flame) shall not be used.

- **Leak detection methods**

The following leak detection methods are deemed acceptable for systems containing flammable refrigerants. Electronic leak detectors shall be used to detect flammable refrigerants, but the sensitivity may not be adequate, or may need re-calibration. (Detection equipment shall be calibrated in a refrigerant-free area.) Ensure that the detector is not a potential source of ignition and is suitable for the refrigerant used. Leak detection equipment shall be set at a percentage of the LFL of the refrigerant and shall be calibrated to the refrigerant employed and the appropriate percentage of gas (25 %maximum) is confirmed. Leak detection fluids are suitable for use with most refrigerants but the use of detergents containing chlorine shall be avoided as the chlorine may react with the refrigerant and corrode the copper pipe-work. If a leak is suspected, all naked flames shall be removed/ extinguished. If a leakage of refrigerant is found which requires brazing, all of the refrigerant shall be recovered from the system, or isolated (by means of shut off valves) in a part of the system remote from the leak. Oxygen free nitrogen (OFN) shall then be purged through the system both before and during the brazing process.

- **Removal and evacuation**

When breaking into the refrigerant circuit to make repairs or for any other purpose conventional procedures shall be used. However, it is important that best practice is followed since flammability is a consideration. The following procedure shall be adhered to: Remove refrigerant; Purge the circuit with inert gas; Evacuate; Purge again with inert gas; Open the circuit by cutting or brazing. The refrigerant charge shall be recovered into the correct recovery cylinders. The system shall be flushed with OFN to render the unit safe. This process may need to be repeated several times. Compressed air or oxygen shall not be used for this task. Flushing shall be achieved by breaking the vacuum in the system with OFN and continuing to fill until the working pressure is achieved, then venting to atmosphere, and finally pulling down to a vacuum. This process shall be repeated until no refrigerant is within the system. When the final OFN charge is used, the system shall be vented down to atmospheric pressure to enable work to take place. This operation is absolutely vital if brazing operations on the pipe-work are to take place. Ensure that the outlet for the vacuum pump is not close to any ignition sources and there is ventilation available.

- **Charging procedures**

In addition to conventional charging procedures, the following requirements shall be followed. Ensure that contamination of different refrigerants does not occur when using charging equipment. Hoses or lines shall be as short as possible to minimise the amount of refrigerant contained in them.

Cylinders shall be kept upright.

Ensure that the refrigeration system is earthed prior to charging the system with refrigerant.

Label the system when charging is complete (if not already).

Extreme care shall be taken not to overfill the refrigeration system. Prior to recharging the system it shall be pressure tested with OFN. The system shall be leak tested on completion of charging but prior to commissioning. A follow up leak test shall be carried out prior to leaving the site.

- **Decommissioning**

Before carrying out this procedure, it is essential that the technician is completely familiar with the equipment and all its detail. It is recommended good practice that all refrigerants are recovered safely. Prior to the task being carried out, an oil and refrigerant sample shall be taken in case analysis is required prior to re-use of reclaimed refrigerant. It is essential that electrical power is available before the task is commenced.

a) Become familiar with the equipment and its operation.

b) Isolate system electrically.

c) Before attempting the procedure ensure that: Mechanical handling equipment is available, if required, for handling refrigerant cylinders; All personal protective equipment is available and being used correctly; The recovery process is supervised at all times by a competent person; Recovery equipment and cylinders conform to the appropriate standards.

d) Pump down refrigerant system, if possible.

e) If a vacuum is not possible, make a manifold so that refrigerant can be removed from various parts of the system.

f) Make sure that cylinder is situated on the scales before recovery takes place.

g) Start the recovery machine and operate in accordance with manufacturer's instructions.

h) Do not overfill cylinders. (No more than 80 % volume liquid charge).

i) Do not exceed the maximum working pressure of the cylinder, even temporarily.

j) When the cylinders have been filled correctly and the process completed, make sure that the cylinders and the equipment are removed from site promptly and all isolation valves on the equipment are closed off.

k) Recovered refrigerant shall not be charged into another refrigeration system unless it has been cleaned and checked.

- **Labelling**

Equipment shall be labelled stating that it has been de-commissioned and emptied of refrigerant. The label shall be dated and signed. Ensure that there are labels on the equipment stating the equipment contains flammable refrigerant.

- **Recovery**

When removing refrigerant from a system, either for servicing or decommissioning, it is recommended good practice that all refrigerants are removed safely. When transferring refrigerant into cylinders, ensure that only appropriate refrigerant recovery cylinders are employed. Ensure that the correct number of cylinders for holding the total system charge is available. All cylinders to be used are designated for the recovered refrigerant and labelled for that refrigerant (i.e. special cylinders for the recovery of refrigerant). Cylinders shall be complete with pressure relief valve and associated shut-off valves in good working order. Empty recovery cylinders are evacuated and, if possible, cooled before recovery occurs. The recovery equipment shall be in good working order with a set of instructions concerning the equipment that is at hand and shall be suitable for the recovery of flammable refrigerants. In addition, a set of calibrated weighing scales shall be available and in good working order. Hoses shall be complete with leak-free disconnect couplings and in good condition. Before using the recovery machine, check that it is in satisfactory working order, has been properly maintained and that any associated electrical components are sealed to prevent ignition in the event of a refrigerant release. Consult manufacturer if in doubt. The recovered refrigerant shall be returned to the refrigerant supplier in the correct recovery cylinder, and the relevant Waste Transfer Note arranged. Do not mix refrigerants in recovery units and especially not in cylinders. If compressors or compressor oils are to be removed, ensure that they have been evacuated to an acceptable level to make certain that flammable refrigerant does not remain within the lubricant. The evacuation process shall be carried out prior to returning the compressor to the suppliers. Only electric heating to the compressor body shall be employed to accelerate this process. When oil is drained from a system, it shall be carried out safely.

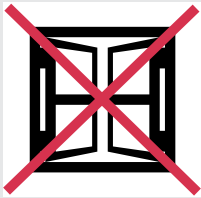

Exposed to the weather outdoors



Near water



If the power cable wires are frayed or cut



Where small children may be left unattended

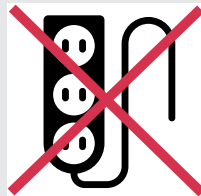

No extension leads or power boards



Where the power cable may be damaged



On a slope or uneven surface



Where there is risk of fire or close to a naked flame



Where it may be damaged by chemicals



Where there is a risk of interference by foreign objects



This product is not made for DIY repair



If there is a risk of water falling on the unit

Specification

Model no.	DC12DE	DC12DEPUR
Power supply	220-240V~, 50Hz	
Dehumidification capacity at 32°C, 80% RH	12L	
Operating Temperature	5-32°C	
Modes	4	
Refrigerant	R290	
Water Tank	1.5L	
Timer	24 hours	
Air Purification	N	Y
Filter	Dust	Dust & HEPA & Active Carbon
Size (WxDxH) mm	195 x 280 x 386mm	
N.W. kg	9.7kg	

Note. When the dehumidifier is in operation, the running compressor will produce heat, this is normal and may potentially raise the room temperature.

How It Works

This product is a dehumidifier. It controls relative humidity by passing the air through the unit, forcing the excess moisture to condensate over the cooling elements. Contact with this cold surface causes the moisture in the air to condense. This condensed water then drains safely into the water tank. The dried air then passes through the condenser where it is slightly warmed and re-enters the room at a slightly elevated temperature.

Where To Position

Excess moisture will travel throughout your home, in the same way that cooking smells waft to every room in the house. For this reason, the dehumidifier should be positioned, so that it can draw this moist air towards it from all over the home. Alternatively, if you have a serious problem in one area you can begin by positioning the dehumidifier close to this area and later moving it to a more central point.

When positioning the dehumidifier, ensure that it is placed on a level surface and that there is a minimum of 45 cm of space on either side of the unit to allow for efficient airflow.

This dehumidifier is fitted with castors for extra mobility, if you move the unit, it should first be switched off and the water tank emptied. We do not recommend the use of an extension lead, so please try to ensure that the unit is sufficiently close to a fixed mains socket.

When the dehumidifier is in operation, outside doors and windows should be closed for most effective and efficient operation.

Parts

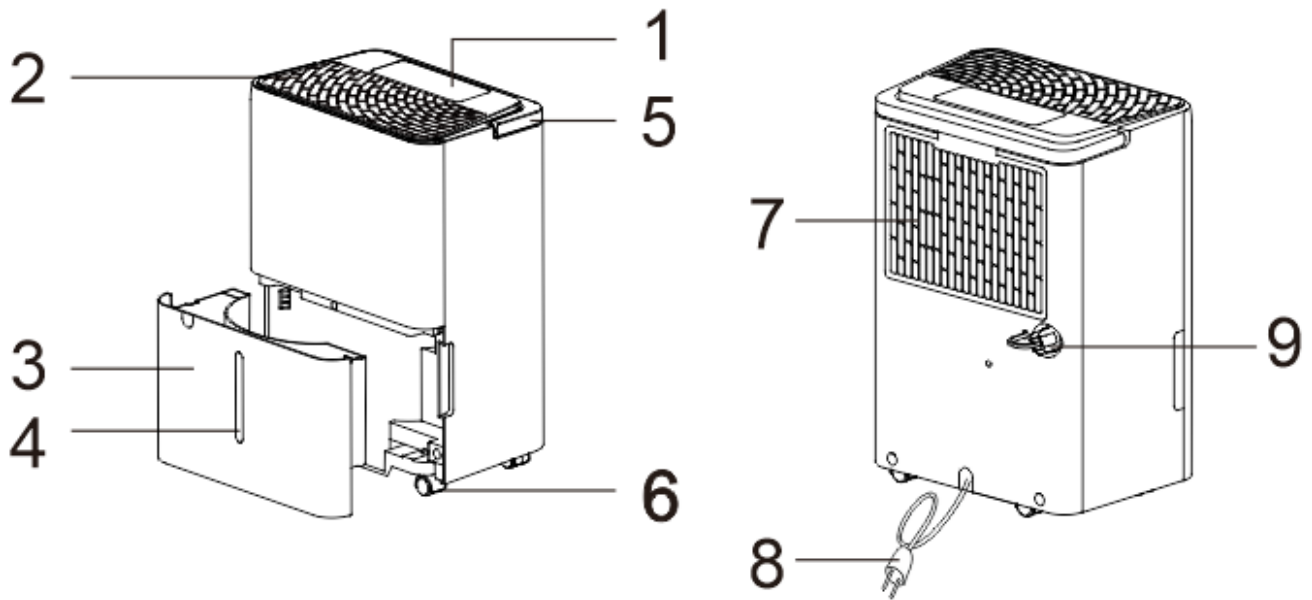

1	Control Panel
2	Air Outlet
3	Water Tank
4	Water Level
5	Handle
6	Castor
7	Air Inlet
8	Power Cord
9	Drainage Port

Accessories

Note: Before use, please ensure to remove the water tank from the appliance, take out the plug and any other accessories and then place the tank back into the slot.

Accessories

- x1 Plug 
- x1 Drain Pipe 

1. Remove the water tank from the slot and then remove all accessories from inside it.
2. Install the chip onto the water tank as per below.

Note: The plug is used to cover the hole left after taking out the power cord when unpacking.

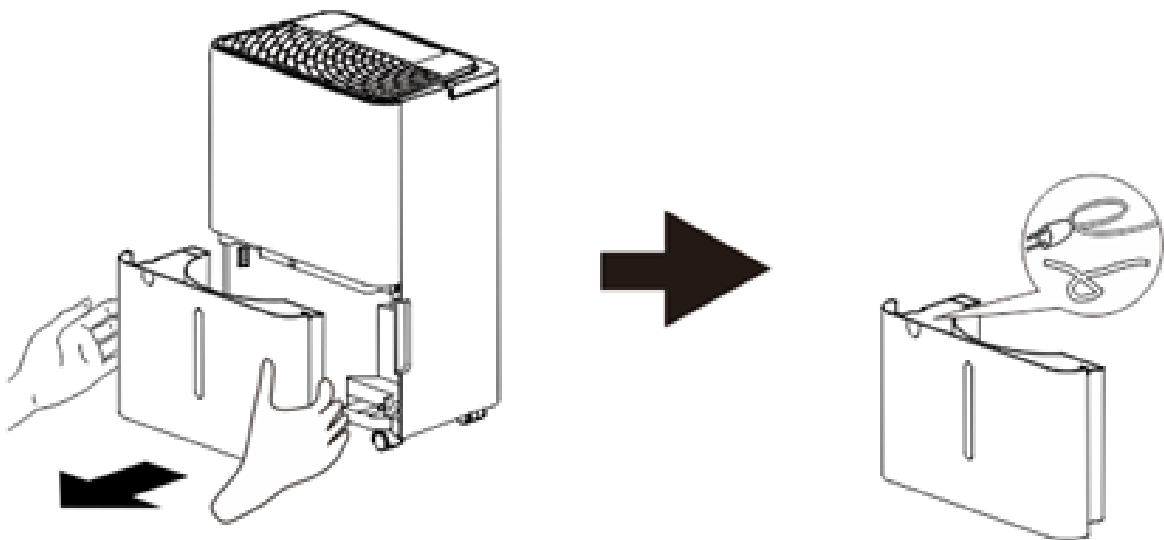

Control Panels

DC12DE

Decrease

Increase

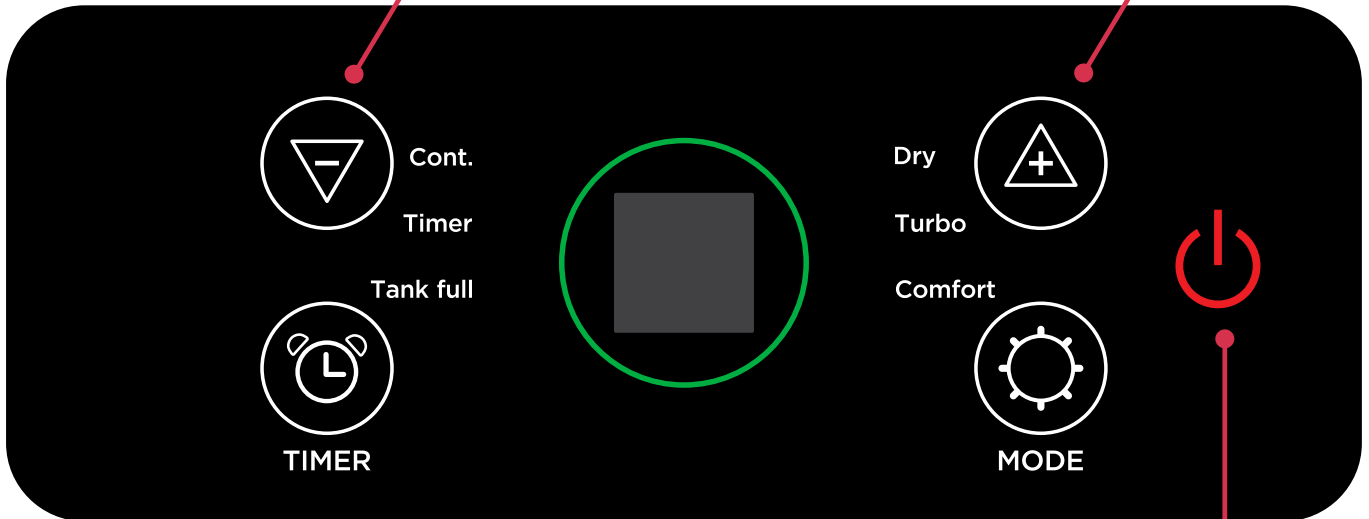

Cont.
Timer

Tank full
TIMER

Dry
Turbo

Comfort
MODE



On/Off

DC12DEPUR

Decrease

Increase

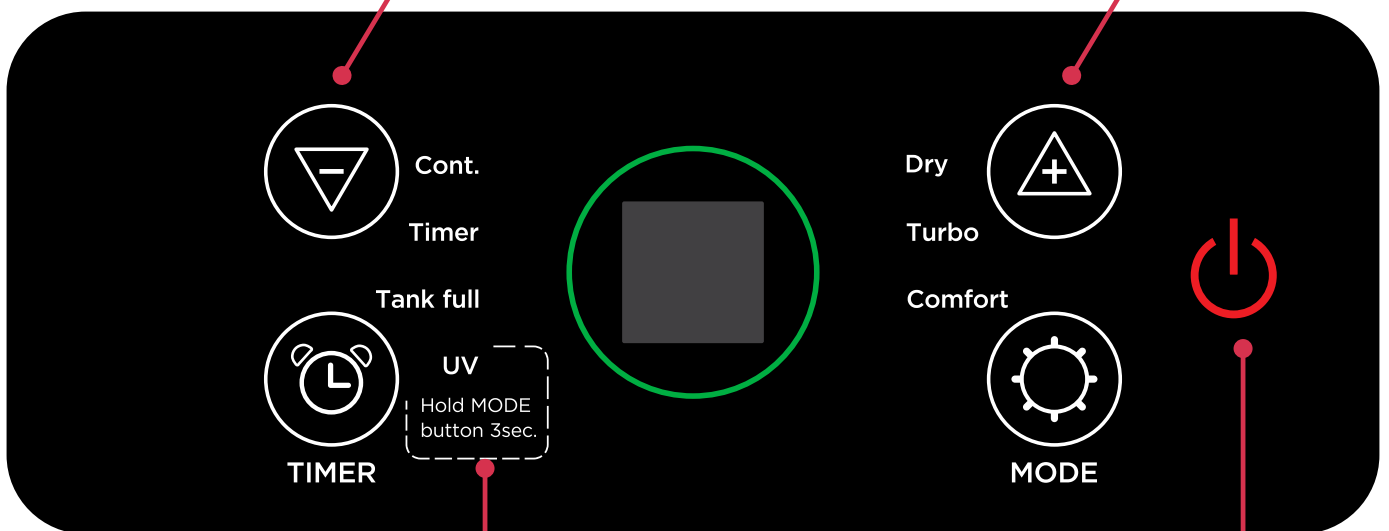

Cont.
Timer

Tank full
TIMER

UV
Hold MODE
button 3sec.

Dry
Turbo

Comfort
MODE



On/Off

Purification

1. Press the **ON/OFF** button to control the start up or shut down of the unit. When using this button to shut down the unit, please note that the fan will keep running for another 3 minutes, in order for the unit to blow dry itself and prevent mold from forming.
2. The **INCREASE** and **DECREASE** buttons are used to select your desired indoor humidity level or set the time on timer mode. These buttons will increase or decrease the humidity or time in increments of 1.
3. Press the **MODE** button to select between the 4 modes.
 - **DRY** Mode - Press the mode button until the '**DRY**' indicator light is on. Press the **INCREASE** or **DECREASE** buttons to choose your desired humidity level. The adjustable range is 35%RH-80%RH. The screen will display the set humidity, and after two seconds, display the ambient humidity. When the ambient humidity is lower than the set humidity, the compressor will stop running and after a few minutes, the fan will also stop running. On this mode, the fan speed is set on low and cannot be adjusted.
 - **TURBO** Mode - Press the mode button until the '**TURBO**' indicator light is on. Press the **INCREASE** or **DECREASE** buttons to choose your desired humidity level. The setting humidity is 35%RH. The screen will display the set humidity, and after 2 seconds, show the ambient humidity. On this mode, the fan speed is set to high and cannot be adjusted.
 - **COMFORT** Mode - Press the mode button until the '**COMFORT**' indicator light is on. On this mode, the appliance will automatically begin setting the humidity according to the ambient temperature. The humidity cannot be adjusted manually. The ambient temperature will show on the display, and the fan speed is set to low and cannot be adjusted. Whilst this mode is in function, the screen lights will go dim, and then turn off after 1 minute. If you want to check the status of the device, press any other button for the screen to light up again. After 1 minute, if left on this mode, the lights will turn off again.
 - **CONTINUOUS** Mode - Press the mode button until the '**CONT**' indicator light is on. On this mode, the setting humidity is 15%RH and cannot be adjusted. The unit will continuously run, and the fan speed is set to low and cannot be adjusted.
4. Press the **TIMER** button to delay the unit to start up or shut down. This helps to avoid wasting electricity by optimising operating periods.
 - **PROGRAM START UP** - Press the **TIMER** button, and the screen will begin to flash. Press the **INCREASE** or **DECREASE** buttons to adjust the time from 0.5-24 hours. After 5 seconds, the timer will start and the '**TIMER**' indicator light will turn on. The display will count down the time remaining until the unit will start up. When the appliance turns on, it will work in default state. The humidity will be set to 50%RH and the fan speed will be low. Press the **TIMER** button again to cancel this function.
 - **PROGRAM SHUT DOWN** - When the appliance is running, press the **TIMER** button and the screen will begin to flash. Press the **INCREASE** or **DECREASE** button to adjust the set time from 0.5-24 hours. After 5 seconds, the timer will start, and the '**TIMER**' indicator light will turn on. The unit will run until the timer is finished. Press the **TIMER** button again to cancel the function.

Note: The following function is only applicable to the **DC12DEPUR** model.

WARNING: The DC12DEPUR model contains a UV-C lamp. Please ensure to read the maintenance instructions before opening the appliance. If the UV-C lamp has an error, please contact a service professional to fix. The appliance must be disconnected from the power supply before replacing the UV-C lamp. Before opening panels bearing the Ultraviolet Radiation hazard symbol for conducting user maintenance as below, it is recommended to disconnect the power.

WARNING: DO NOT operate the UV-C lamp outside of the appliance. Unintended use of the appliance or damage to the housing may result in the escape of dangerous UV-C radiation. UV-C radiation, even in small doses, may cause harm to the eyes and skin. Appliances that are damaged in any way should not be operated. UV-C barriers containing the Ultraviolet radiation hazard symbol should not be removed. Do not stare directly at the light source.

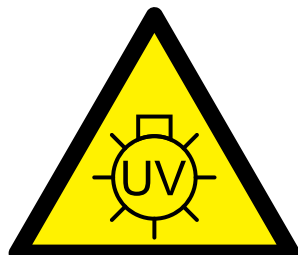

- Hold the **MODE** button for 3 seconds to activate the **PURIFICATION** function. The **'UV'** symbol will display.
- Hold the **MODE** button for a further 3 seconds to switch this function off. The **'UV'** symbol will disappear from the display.

This function uses Ultra Violet (UV) Light disinfection to purify and remove microbiological contaminants from the humidity in the air.

Water Tank Full Alarm

When the water tank is full, the compressor will shut off, the fan will stop and the unit will begin to make a 'beeping' noise. The 'TANK FULL' indicator light will begin to flash.

Note: Please ensure to hold the water tank with both hands when emptying.

Note: The unit will not run again until the water tank is emptied and properly placed back into the unit. The tank should be cleaned every week to prevent the growth of mold, mildew and bacteria. Use a mild detergent to clean. Once clean, ensure to completely dry the tank before placing back into the unit.

Note: When the tank is full or removed from the unit, the fan will continue to run for a few minutes before turning off. This is normal, and the unit will not be removing moisture from the air at this time.

Note: During operation, it is normal for the device to exhaust warm air from the side of the unit.

CAUTION: Do not place the water tank on the floor when it is full, as it is uneven on the bottom and this can cause spillage.



Drainage

Continuous Drainage

Connect the drain pipe onto the back of the unit.

1. Place the unit on level flooring and unscrew the cap on the back of the unit.
2. Install the connector chip of the drain and gasket.
3. Install the drain pipe onto the connector chip.
4. Press the ON/OFF button to run the unit.

Note: If you do not require the function of the continuous drainage any longer, install the cap on the drain hole on the back of the unit and the water will begin to flow back into the tank.

Note: If you place the unit on un-even flooring or do not correctly install the drain pipe, the water will fill the tank and the drainage will not work. Ensure to check the ground is level and the pipe and tank are correctly installed as below.

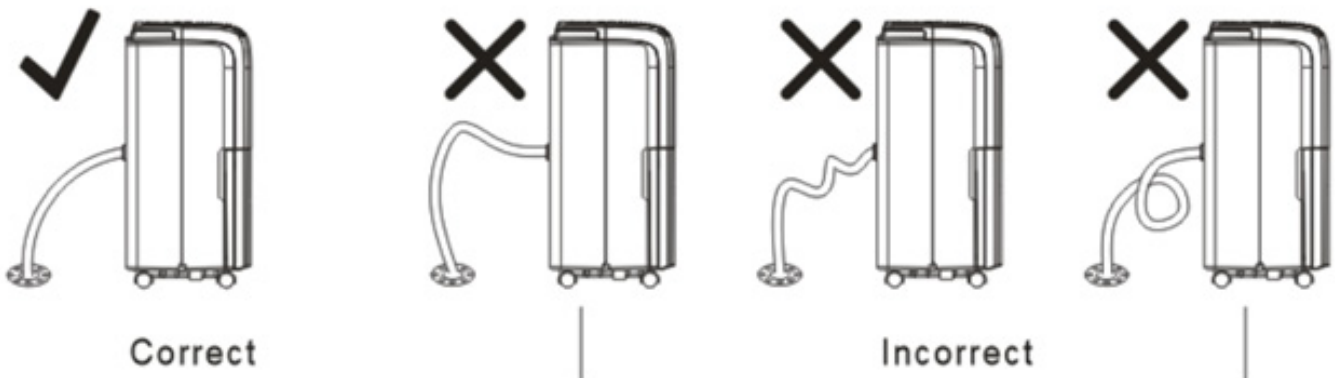
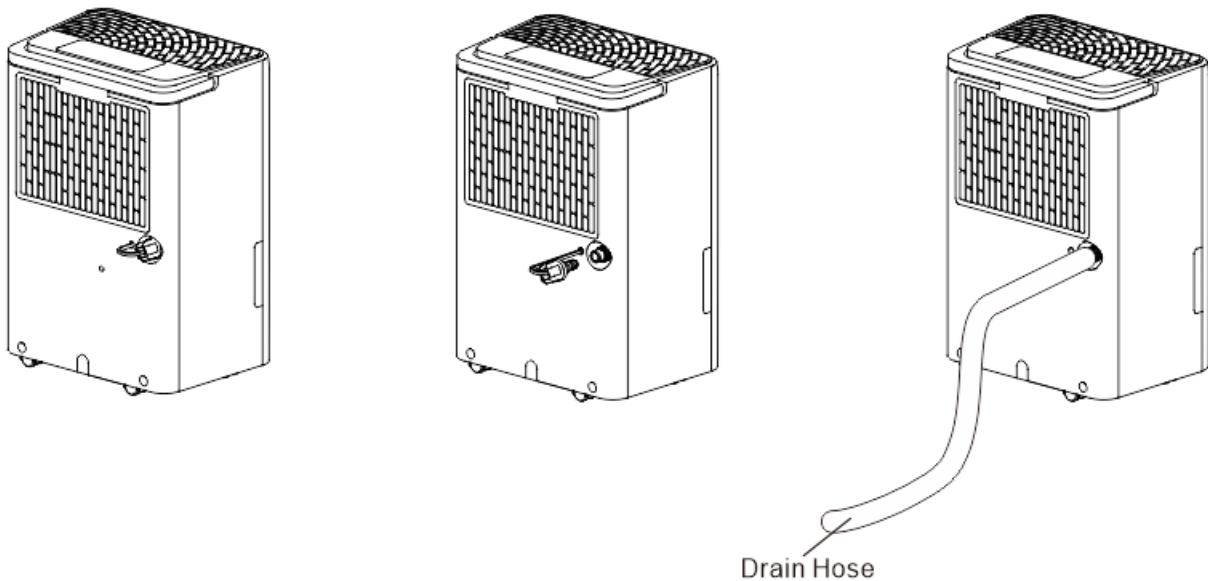

Automatic Defrost

Automatic Defrost Function

When frost builds up on the evaporator coils, the compressor will stop and the fan will continue to run until the frost disappears. When the coils are completely defrosted, the compressor will automatically restart and the dehumidifying will resume.

Cleaning

Before cleaning or maintenance, turn the appliance off by pressing the ON/OFF button on the control panel. Wait a few minutes, then unplug the cord from the mains socket.

Cleaning the cabinet

You should clean the cabinet with a slightly damp cloth and then dry with a dry cloth.

- Never wash the appliance with water, this is a safety hazard.
- Never use petrol, alcohol or solvents to clean the appliance.
- Never spray insecticide liquids or anything similar on the device.

Cleaning the filter

- To keep your appliance working efficiently, you should clean the filter every month of operation. See below image of how to take the filter out.
- To avoid possible cuts, avoid contacting the metal parts of the appliance when removing or re-installing the filter. This can result in injury.
- Use a vacuum cleaner to remove the accumulation of dust from the filter. If it is very dirty, immerse in warm water and rinse a number of times. The water should never be hotter than 40°C. After washing, leave the filter to dry and then attach the intake grille to the appliance.
- It is recommended to replace the filter every 3 months. Filters can be purchased from the Dimplex spare parts shop on the website.

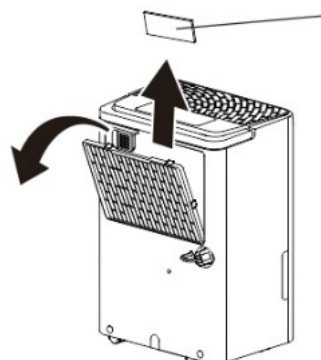

Cleaning

Note: If you do not plan on using the device for an extended period of time, ensure to:

- Unplug the device from the mains socket.
- Empty the water tank and remove the cap.
- Clean the filter and dry thoroughly before putting back.
- Cover the appliance to prevent dust.
- Store the appliance upright in a dry location.

Note: After an extended period of time, when you plan on using the device again, ensure to:

- Check the power cord and plug are both undamaged and the earth system is efficient.
- Follow the installation instructions precisely.

THE UNIT DOES NOT OPERATE:

- Is the unit plugged in?
- Is the fuse blown or circuit breaker tripped?
- Is the water tank full or has the dehumidifier reached its present level?
- Is the water tank in the proper position?
- Has the unit experienced a power failure?
- Ensure the dehumidifier's plug is pushed completely into the outlet.
- Check the house fuse/circuit breaker box and replace fuse or reset breaker.
- The dehumidifier will automatically turn off when the water tank is full or it is exhausted. Change to a lower setting or empty the water tank and replace properly.
- Check the water tank is installed correctly.
- This unit has a protective time delay of up to 3 minutes to prevent tripping of the compressor and overload. For this reason, the unit may not start normal dehumidifying functionality for 3 minutes after it is powered back on.

THE DEHUMIDIFYING FUNCTION DOES NOT WORK:

- Was enough time allowed for moisture removal?
- Is the airflow restricted?
- Is the filter dirty?
- Is the humidity level set low enough?
- Are all doors and windows closed?
- Is the unit set up near a clothes dryer?
- Is the room temperature too low?
- When the unit is first installed, allow 24 hours to maintain the desired dryness level.
- Ensure there are no curtains, blinds or furniture blocking the back of the dehumidifier.
- Ensure the filter is clean.
- Set the humidity level lower on the device.
- Shut all doors, windows and openings.
- Ensure the room temperature is above 5°C.

THE UNIT RUNS FOR TOO LONG:

- Is the room too large?
- Are doors and windows open?
- If the room size is too large, the capacity of the appliance will not be able to meet the area of the room. Move to a smaller room.
- Ensure doors, windows and openings are shut.

FROST APPEARS ON THE HEAT EXCHANGER:

- Has the appliance run recently or is the room temperature too low?
- This is normal and the frost should disappear after one hour.

WATER ON THE FLOOR:

- Is the drain connection ageing or loose?
- Is the unit not draining water despite the drain pipe being connected?
- Check the drain connection and the appliance are placed level.
- Remove the drain pipe and place the cover back on. Drain using the tank.
- Ensure the drain pipe is installed correctly.

Trouble shooting

ERROR CODES:

- **EH** - Humidity Sensor Failure
- **E2** - Temperature Sensor Failure



Recycling: Do not dispose of electrical appliances as unsorted municipal waste. Use separate collection facilities. Contact your local government for information regarding the collection systems available. If electrical appliances are disposed of in landfills or dumps, hazardous substances can leak into the ground water, polluting the food chain and damaging health and well-being.



Customer Care: 1300 556 816
customer care@glendimplex.com.au
www.dimplex.com.au

Supplied by Glen Dimplex Australia
1340 Ferntree Gully Road, Scoresby, Victoria, 3179

© Glen Dimplex Australia. All rights reserved. Material contained in this publication may not be reproduced in whole or in part, without prior permission in writing of Glen Dimplex Australia.

DC12DE & DC12DEPUR v1