

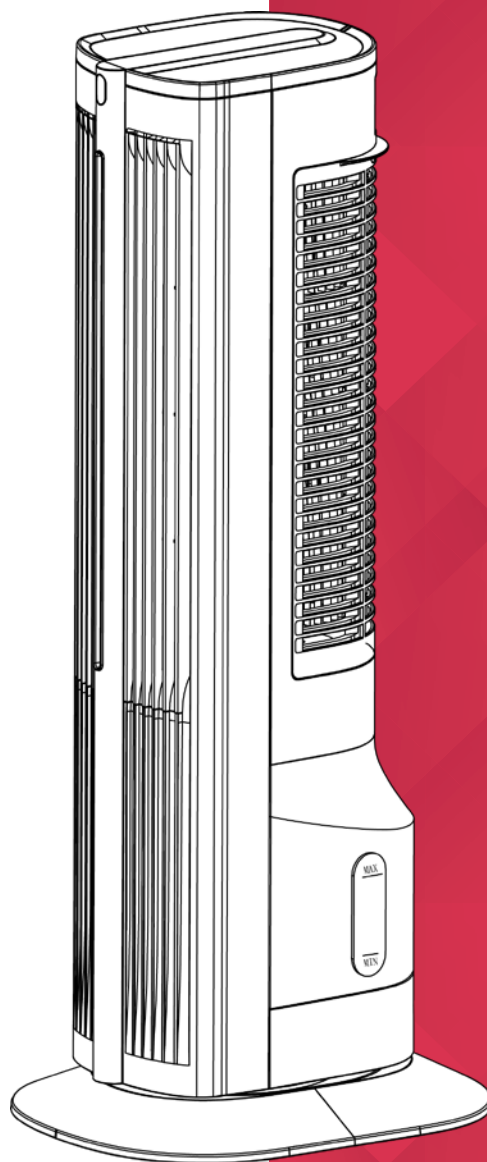

INSTRUCTION MANUAL



Heat/Cool/Humidifier Tower Fan

Model: DCTF3HCH

For domestic household use only.



IMPORTANT

THESE INSTRUCTIONS SHOULD BE READ CAREFULLY AND RETAINED FOR FUTURE REFERENCE.

Note also the information presented on the appliance

CAUTION: FAILURE TO FOLLOW THESE INSTRUCTIONS MAY CAUSE INJURY AND/OR DAMAGE AND MAY INVALIDATE YOUR WARRANTY

Please read the operating instructions carefully before using your tower fan for the first time and keep them in a safe place.

WARNING - This appliance must not be used in a bathroom.

WARNING - Do not use this appliance in the immediate surroundings of a bath, a shower or a swimming pool.



WARNING - In order to avoid overheating, do not cover this heater.

WARNING - Do not use this heater in small rooms when they are occupied by persons not capable of leaving the room on their own, unless constant supervision is provided.

WARNING - To reduce the risk of fire, keep textiles, curtains, or any other flammable material a minimum distance of 1 metre from the air outlet.

WARNING - In order to avoid a hazard due to inadvertent resetting of the thermal cut-out, this appliance must not be supplied through an external switching device, such as a timer, or connected to a circuit that is regularly switched on and off by the utility.

WARNING - Some parts of this unit can become very hot and cause burns. Particular attention has to be given where children and vulnerable people are present.

- If the supply cord is damaged it must only be replaced by the manufacturers service agent or a similarly qualified person in order to avoid a hazard.
- This appliance is not intended for use by persons (including children) with reduced physical, sensory or mental capabilities, or lack of experience and knowledge, unless they have been given supervision or instruction concerning use of the appliance by a person responsible for their safety.
- Children should be supervised to ensure they do not play with the appliance.
- Prior to cleaning or other maintenance, the appliance must be disconnected from the supply mains.
- Never immerse the appliance in water or other liquids.
- Do not place on soft, unstable or non-horizontal/angled surfaces.
- Never operate the appliance if a cable or connector has been damaged, after appliance malfunction or if the appliance was dropped or is otherwise damaged.
- Please ask a professional service agent to repair the product. Improper repair may cause danger to users.

- Disconnect the appliance from mains power whenever it is not in use, before relocating it, and before cleaning.
- Operate the appliance only at the voltage specified on the rating label.
- Only connect the unit to a properly installed and easily accessible socket so that you can quickly disconnect the plug if necessary.
- Do not connect this product to the mains using an extension lead.
- This product is only intended for **INDOOR RESIDENTIAL** applications. This tower fan should not be used for commercial or industrial or leisure applications or in small enclosed spaces.
- Never use the mains lead as a carrying strap or pulling lead.
- To avoid a fire or electrocution hazard, **NEVER** put the cord near heat registers, radiator, stoves or heaters.
- **DO NOT** cover cord with carpeting, throw rugs, runners, or similar coverings.
- **DO NOT** route cord under furniture or appliances. Take care to position the cord away from traffic areas and where it will not be a tripping hazard.
- **DO NOT** use the unit near windows or where water collects. Rain and water collection may lead to a risk of fire or electric shock.
- **DO NOT** use this heater if it has been dropped.
- **DO NOT** use if there are visible signs of damage to the heater.
- The heater must not be located immediately below a fixed socket outlet.
- **WARNING** - To avoid danger of suffocation please remove all packaging materials particularly plastic and EPS and keep these away from vulnerable people, children and babies.
- **NEVER** drop or insert any object or fingers into any openings.
- Do not use the appliance in locations where paint, petrol or other flammable liquids are used or stored.
- Do not use bug sprays or other flammable cleansers/vapour sprays on or around the unit.
- Always switch off the unit and take the plug out of the socket:
 - If you are not using the unit
 - Before you clean or carry out maintenance on the unit
 - If a fault occurs
 - In the event of an electrical storm.
- Avoid electromagnetic interference, keep the unit at least 1 metre away from electrical appliances such as televisions & radios.
- Use this heater on a horizontal and stable surface.
- Children shall not plug in, regulate and clean the appliance or perform user maintenance.



WARNING - DO NOT COVER the heater in any manner as it may overheat and become a fire risk.

- Ensure the water quality is pure and below 40°C when utilising the humidifying function.
- Ensure water is being added to the appliance slowly with the use of a container to avoid overflowing and exceeding the maximum water level.
- Ensure the cover of the water tank is tightly closed when in operation.
- The surface of the appliance must be kept dry. If you notice overflow, disconnect the appliance immediately and dry before use again.
- If water droplets are blocking the spray port, wipe gently to remove before use again.
- **DO NOT** allow water or other liquids to enter the interior of the heater. This may cause a fire or an electric shock hazard.
- **DO NOT** try to disassemble and repair this product by yourself shall a problem occur. Doing so can cause an electric shock hazard.
- **DO NOT** use this appliance with an extension lead or power board.

WARNING: KEEP BATTERIES OUT OF REACH OF CHILDREN

- Swallowing may lead to serious injury in as little as 2 hours or death, due to chemical burns and potential perforation of the oesophagus.
- If you suspect your child has swallowed or inserted a button battery immediately call the 24-hour Poisons Information Centre on 13 11 26 (in Australia) or 0800 764 766 (in New Zealand) for fast, expert advice.
- Examine devices and make sure the battery compartment is correctly secured, e.g. that the screw or other mechanical fastener is tightened. Do not use if the compartment is not secure.
- Dispose of used button batteries immediately and safely. Flat batteries can still be dangerous.

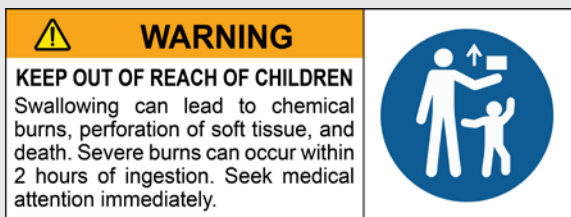

CAUTION: No obvious symptoms

Unfortunately, it is not obvious when a button or coin battery is stuck in a child's oesophagus (food pipe).

There are no specific symptoms associated with this. The child might:

- cough, gag or drool a lot
- appear to have a stomach upset or virus
- be sick
- point to their throat or stomach
- have a pain in their abdomen, chest or throat
- be tired or lethargic
- be quieter or more clingy than usual or otherwise 'not themselves'
- lose their appetite or have a reduced appetite
- not want to eat solid food/be unable to eat solid food

These types of symptoms vary or fluctuate, with the pain increasing and then subsiding.

A specific symptom to button and coin battery ingestion is vomiting fresh (bright red) blood. If the child does this seek immediate help. The lack of clear symptoms is why it is important to be vigilant with 'flat' or spare button or coin batteries in the home and the products that contain them.



Exposed to the weather outdoors



Near water



If the power cable wires are frayed or cut



Where small children may be left unattended

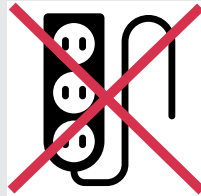

No extension leads or power boards



Where the power cable may be damaged



On a slope or uneven surface



Where there is risk of fire or close to a naked flame



Where it may be damaged by chemicals



Where there is a risk of interference by foreign objects



This product is not made for DIY repair



If there is a risk of water falling on the unit

Specification

Model no.	DCTF3HCH
Power supply	220-240V-50Hz
Rated power	13.8W (cooling) 2000W (heating)
Speed settings	2
Heat settings	2
Timer	12 hours
Mist output	120ml/h
Adjustable temperature	20-30°C
Water tank	1.5L
Oscillation	85°
Noise level (MAX)	55dB(A)
Weight (net)	3.6kg
Dimensions (w x d x h)	228 x 285 x 672mm

- For greater precision, please always refer to the rating label placed on the product.

Parts

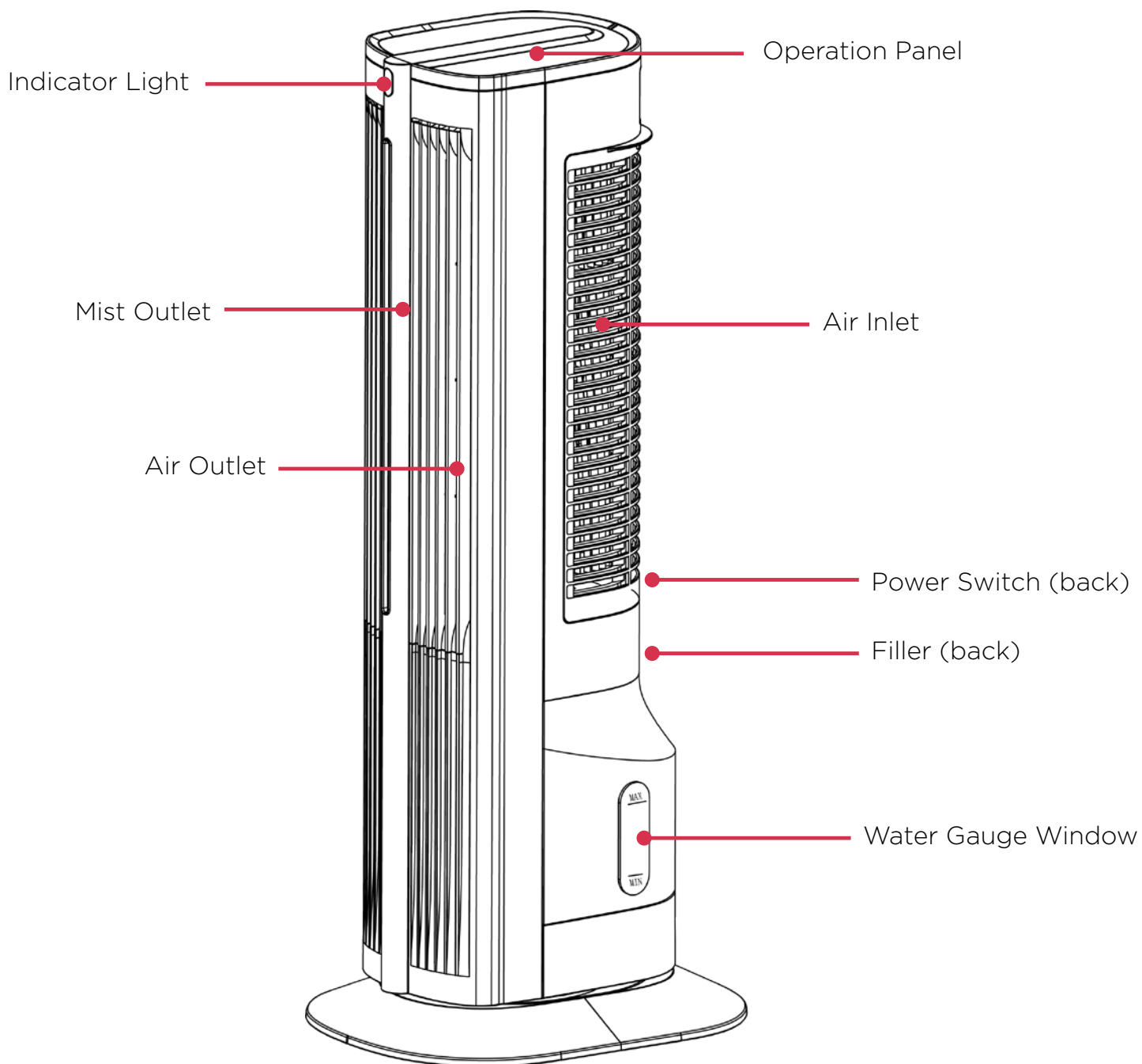

Control Panel

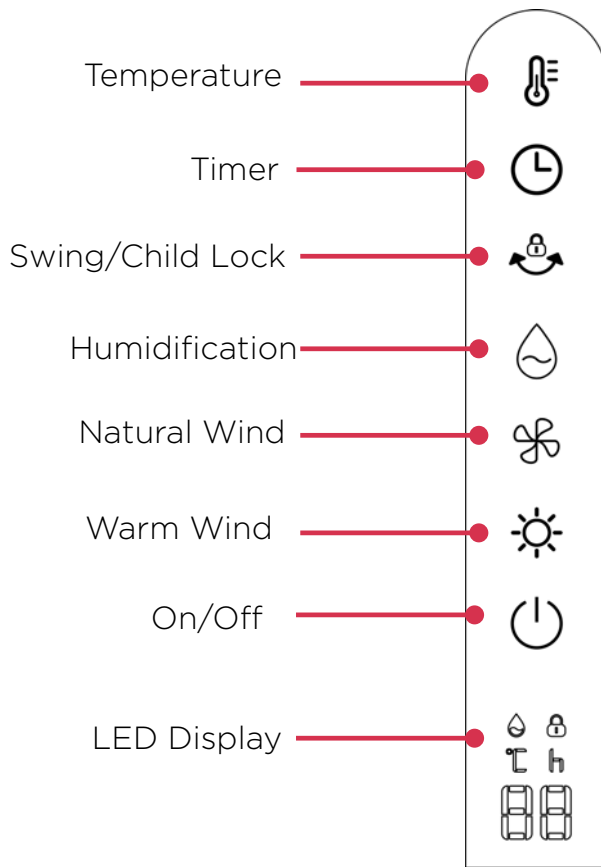

Remote Control

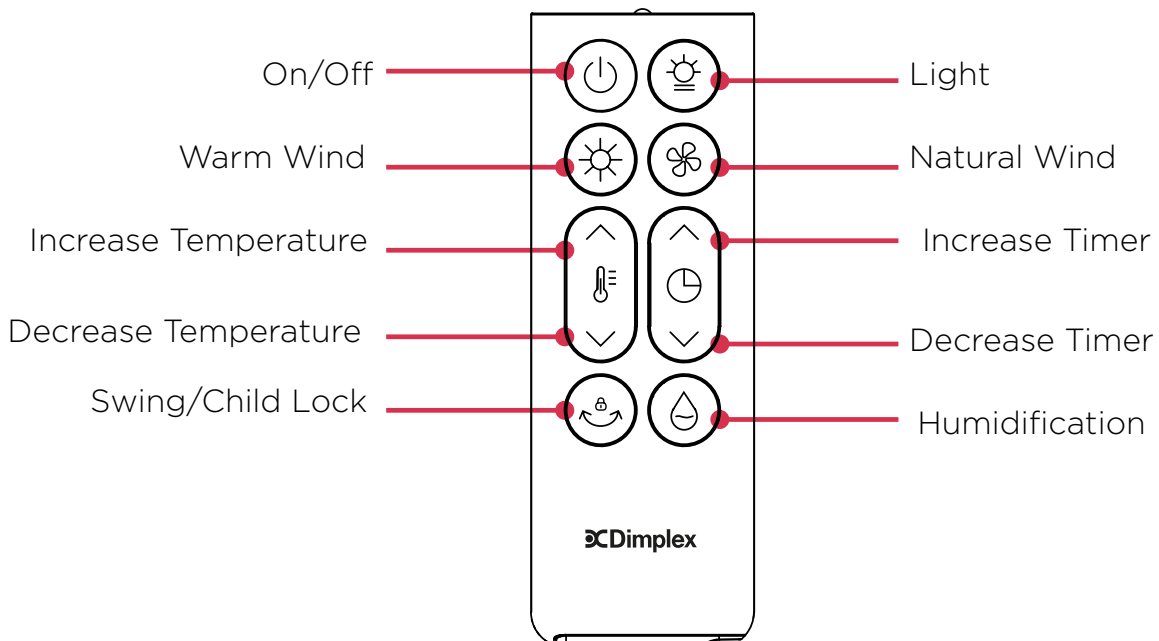

Assembly

1. Take the base of the Tower Fan, and align it to the bottom of the unit.
2. Fix the base onto the bottom of the unit using the four included screws.
3. The Tower Fan should look as per below (image 3). When the device is not in use, place the remote control in the housing space on the top of the unit.

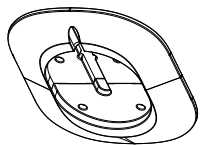

①

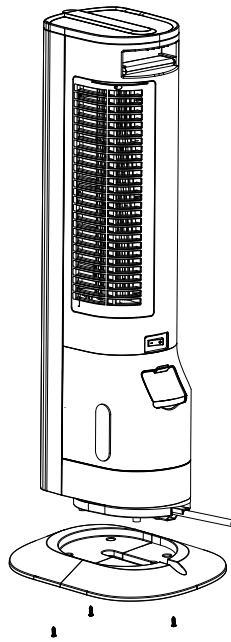

②

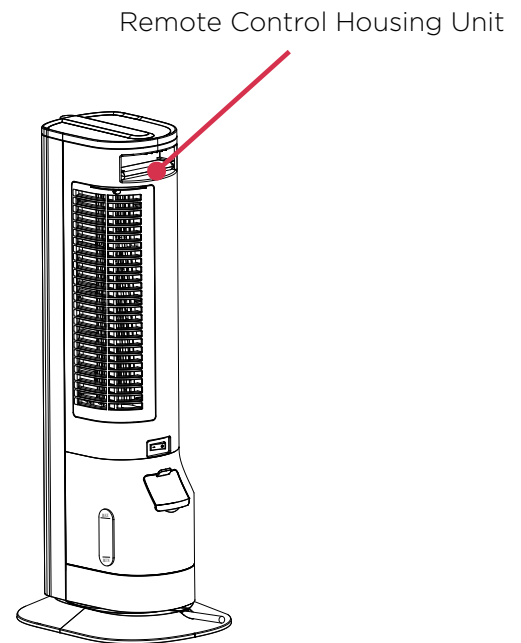

③

Operation

When the power is connected, flick the power switch at the back of the unit to turn the device on. A buzzer noise will ring, and the power indicator light will switch on. You can select different modes by pressing the keys/buttons on the control panel and/or remote control.

1. Press the **ON/OFF** button to turn the device on. The device will begin to run on low fan speed, and the display will show 'C1.' Press this button again to turn the device off. This unit has a memory function, so when you turn the device back on after switching off, it will automatically run on its' last setting.
2. By pressing the **WARM WIND** button, the unit will begin to produce warm air. There are 2 heat settings within this unit. If you click this button once, the unit will run on its low heat setting mode and the display will show 'H1.' If you click this button again, the unit will run on its high heat setting mode, and the display will show 'H2.' Press and hold this button for 3 seconds to stop the function.
3. By pressing the **NATURAL WIND** button, the unit will begin to produce a cool air flow. There are 2 fan speed settings within this unit. If you click this button once, the unit will run on its low fan speed setting, and the display will show 'C1.' If you click this button again, the unit will run on its high fan speed setting, and the display will show 'C2.' Press and hold this button for 3 seconds to stop the function.
4. By pressing the **HUMIDIFICATION** button, the unit will utilise its humidifying function. This button allows the units atomizer to function, and the unit will start to spray mists of water. The display will show a water droplet logo as per above, and when this logo flashes, it means the water tank level is low and needs a fill. When this happens, ensure you press this button again to stop the humidifying function, and then carefully open the water tank cover to slowly add clean tap water (purified water under 40°C). When you add water, please ensure the water

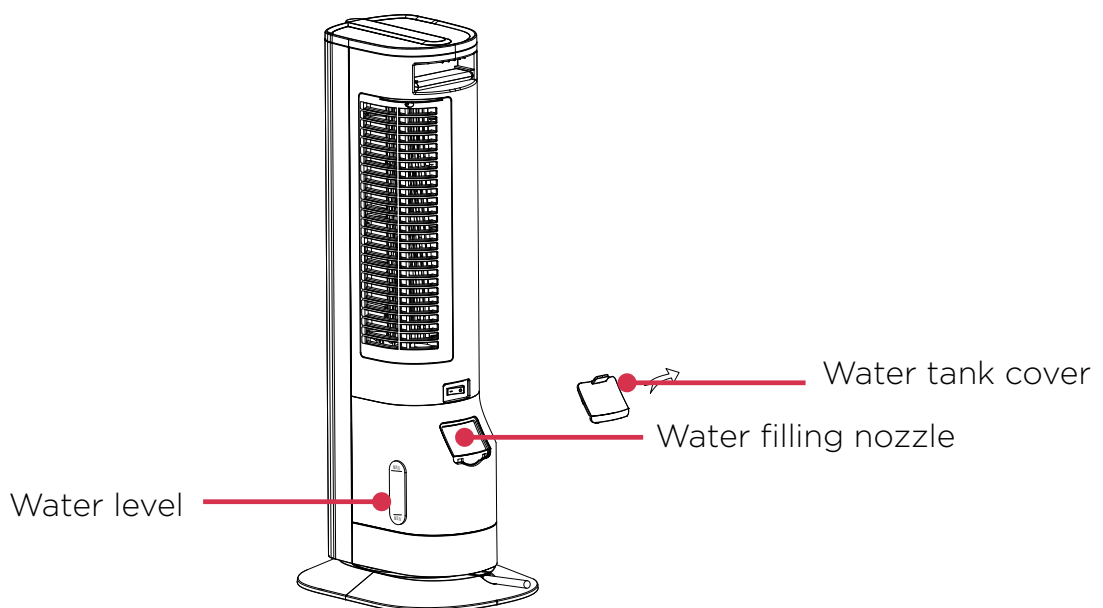

level is between the 'min' mark of the lowest water level line and the 'max' mark of the highest water level line. This will help ensure that the water does not overflow. Ensure that the water tank cover is tight and secure, and the machine surface is dry before further use.

5. When the **WARM WIND/NATURAL WIND** and/or **HUMIDIFICATION** functions are turned on, press the **SWING** button to enable the unit to oscillate up to 85° left and right. Press and hold this button for 3 seconds to enable the **CHILD LOCK** function. In this state, the unit will be locked in whatever settings were previously chosen. To release the unit from this state, press the button for another 3 seconds.
6. When the **WARM WIND/NATURAL WIND** and/or **HUMIDIFICATION** functions are turned on, press the **TIMING** button to set the timer button to start the timer functionality. Use the remote control to increase or decrease the timer between 1-12 hours.
7. When the **WARM WIND** function is turned on, press the **TEMPERATURE-SETTING** button to set the temperature. You are able to set the temperature as 20°C, 22°C, 24°C, 26°C, 28°C or 30°C. When the ambient temperature is higher than the set temperature value, the heating and fan will be turned off after a delay of 15 seconds. When the ambient temperature is lower than the set temperature by 2 degrees, turn on the fan and heating again to heat up.
8. When using the remote control, ensure it is aimed at the receiving window when using. As per above, the remote buttons are consistent with the control panel. The **LIGHT** button on the remote control can be used to independently control the light of the control panel and turn off the screen.

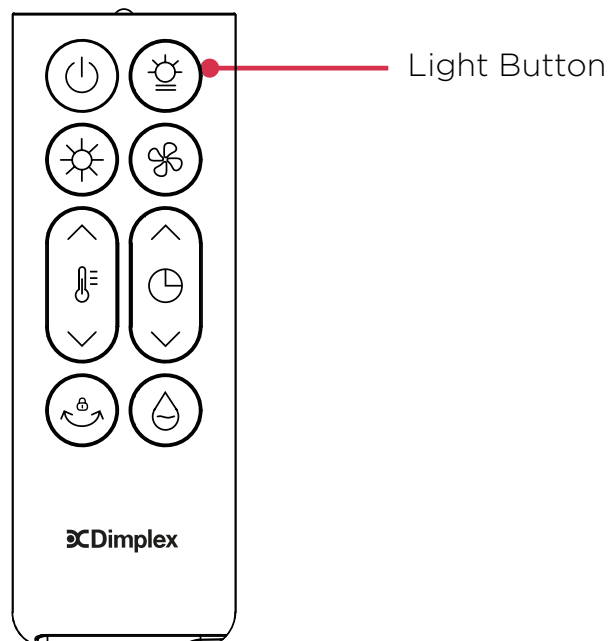

Cleaning

Over time, dust can accumulate on the grille covers, filter (if applicable) and fan blades, which can affect the fans performance. It is recommended to clean the fan at least once a month.

1. Turn the unit OFF and disconnect the appliance from the power supply.
2. Remove any dust build up with a soft brush.
3. Wipe the surface of the unit with a soft damp cloth. Mild detergent can be used for any stubborn marks.

IMPORTANT

When the water tank is dirty, use a brush to clean the inside of the tank and ensure the power is disconnected before cleaning. The control panel and other parts must not come into contact with water or any other liquids.

After long term usage, dust may begin to block the air inlet. Regular maintenance is required to clean this. Disconnect the power supply, unscrew the air inlet and disassemble the inlet grille to open. Use a brush or rinse gently to remove dust. The inlet grille must be completely dry before assembling back onto the fan.

If the mist outlet is blocked after long term usage due to water quality problems, citric acid scale remover can solve this problem. Add citric acid scale remover into the water tank, and then add an appropriate amount of warm water and let it stand for 10-15 minutes. Then, gently shake the water tank and pour out the solution. Add an appropriate amount of water again to clean excess solution.

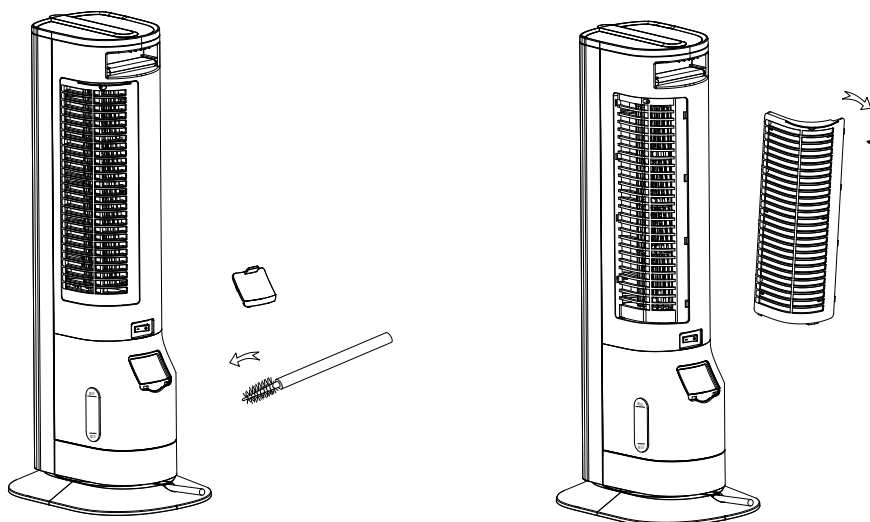

Storage

If not using the unit for an extended period of time. After cleaning please:

- Turn the unit off, unplug and take care of the mains lead & plug.
- Cover the unit and store it upright in a location where it will not receive direct sunlight. NB- Prolonged exposure to direct sunlight will discolour the outer casing.

Symptoms of Battery ingestion

Unfortunately it is not obvious when a button battery or coin is stuck in a child's oesophagus. There is no specific symptom associated with this but the child may display some of the following symptoms:

- Excessive Coughing, Gagging or Drooling
- Appear to have a stomach upset or a virus
- Vomiting
- Indicate to their throat or stomach to signify discomfort
- Abdomen chest or throat pain
- Tired or lethargic
- Quieter or more clingy than usual or otherwise "not themselves"
- Loss or reduced appetite
- Resistance to or incapacity to eat solid food

Symptoms can vary or fluctuate, with pain increasing and subsiding.

A specific symptom to button or coin battery ingestion is vomiting bright red blood.

If your child does this, immediately seek medical assistance.

The lack of clear symptoms is why it is important to be vigilant with "flat" or spare button or coin batteries in the home and the products that contain them.

Maintenance

If the unit fails to operate efficiently, is broken or other problems arise, unplug and do not operate. Ask for advice by calling your local after sales service agent or the Customer Care Centre on 1300 556 816 (AU) / 0800 666 2824 (NZ).

Warranty

Please refer to the warranty card in the box for warranty information. For any troubleshooting advice, please contact the relative Customer Care Centre below.

Glen Dimplex Australia Pty Ltd

8 Lakeview Drive,
Scoresby 3179, Victoria
Australia
Ph: 1300 556 816

Glen Dimplex New Zealand Ltd

38 Harris Road, East Tamaki,
Auckland 2013
New Zealand
Ph: 0800 666 2824



Recycling: Do not dispose of electrical appliances as unsorted municipal waste. Use separate collection facilities. Contact your local government for information regarding the collection systems available. If electrical appliances are disposed of in landfills or dumps, hazardous substances can leak into the ground water, polluting the food chain and damaging health and well-being.



Customer Care: 1300 556 816
customer.care@glendimplex.com.au
www.dimplex.com.au

Supplied by Glen Dimplex Australia
8 Lakeview Drive, Scoresby, Victoria, 3179

© Glen Dimplex Australia. All rights reserved. Material contained in this publication may not be reproduced in whole or in part, without prior permission in writing of Glen Dimplex Australia.