

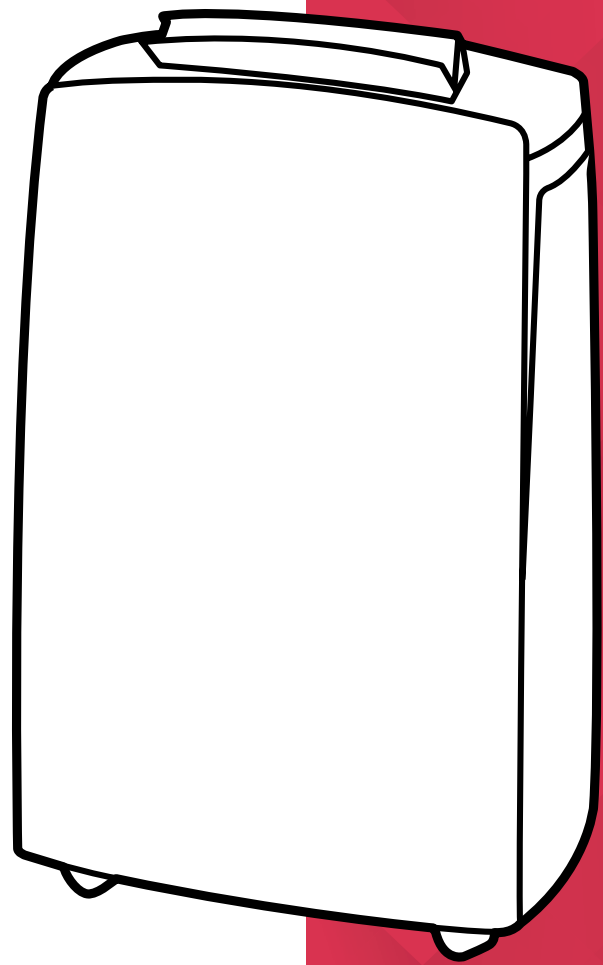

INSTRUCTION MANUAL



Portable Air Conditioner

Model: DCP16C

For domestic household use only.



IMPORTANT

THESE INSTRUCTIONS SHOULD BE READ CAREFULLY AND RETAINED FOR FUTURE REFERENCE.

Note also the information presented on the appliance

CAUTION: FAILURE TO FOLLOW THESE INSTRUCTIONS MAY CAUSE INJURY AND/OR DAMAGE AND MAY INVALIDATE YOUR WARRANTY

Please read the operating instructions carefully before using your Portable Air Conditioner for the first time and keep them in a safe place.

WARNING – This appliance must not be used in a bathroom.

WARNING – Do not use this appliance in the immediate surroundings of a bath, a shower or a swimming pool.

- If the mains lead is damaged it must only be replaced by the manufacturers service agent or a similarly qualified person in order to avoid a hazard.
- This appliance is not intended for use by persons (including children) with reduced physical, sensory or mental capabilities, or lack of experience and knowledge, unless they have been given supervision or instruction concerning use of the appliance by a person responsible for their safety.
- Children should be supervised to ensure they do not play with the appliance.
- Prior to cleaning or other maintenance, the appliance must be disconnected from the supply mains.
- Never immerse the appliance in water or other liquids.
- Operate this unit only on a firm, flat surface to avoid the risk of water leakage. Ensure that the unit is kept upright at all times.
- Do not place on soft, unstable or non-horizontal/angled surfaces.
- Never operate the appliance if a cable or connector has been damaged, after appliance malfunction or if the appliance was dropped or is otherwise damaged.
- Please ask a professional service agent to repair the product. Improper repair may cause danger to users.
- Disconnect the appliance from mains power whenever it is not in use, before relocating it, and before cleaning.
- Operate the appliance only at the voltage specified on the rating label.
- Only connect the unit to a properly installed and easily accessible socket so that you can quickly disconnect the plug if necessary.
- Do not connect this product to the mains using an extension lead.
- This product is only intended for **INDOOR RESIDENTIAL** applications. This product should not be used for commercial or industrial or leisure applications or in small enclosed spaces.
- Never use the mains lead as a carrying strap or pulling lead.
- To avoid a fire or electrocution hazard, **NEVER** put the cord near heat registers, radiator, stoves or heaters.
- **DO NOT** cover cord with carpeting, throw rugs, runners, or similar coverings.
- **DO NOT** route cord under furniture or appliances. Take care to position the cord away from traffic areas and where it will not be a tripping hazard.
- **DO NOT** use the unit near windows or where water collects. Rain and water collection

may lead to a risk of fire or electric shock.

- Only operate this appliance with a minimum of 50cm clearance all around i.e. away from walls, furniture and overhanging objects such as curtains or a shelf.
- **WARNING:** To avoid danger of suffocation please remove all packaging materials particularly plastic and EPS and keep these away from vulnerable people, children and babies.
- **NEVER** drop or insert any object or fingers into any openings.
- Do not cover or obstruct the air inlet and outlets.
- Do not use the appliance in locations where paint, petrol or other flammable liquids are used or stored.
- Do not use bug sprays or other flammable cleansers/vapour sprays on or around the unit.
- Always switch off the unit and take the plug out of the socket:
 - If you are not using the unit
 - Before you clean or carry out maintenance on the unit
 - If a fault occurs
 - In the event of an electrical storm.
- Avoid electromagnetic interference. Keep the unit at least 1 metre away from electrical appliances such as televisions & radios.
- The air conditioner must always be stored and transported upright. In case of doubt we suggest you wait for at least 24 hours before operation. (Please keep unit upright at all times).
- This portable air conditioner is fitted with a compressor delay protection circuit. This protects the unit from possible damage due to rapid starting and stopping of its compressor. The compressor will begin operation 3 minutes after the unit has been switched **ON** or if the mode is changed from dehumidify to cooling.
- The appliance shall be installed in accordance with national wiring regulations.

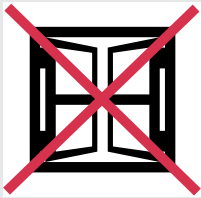

Exposed to the weather outdoors



Near water



If the power cable wires are frayed or cut



Where small children may be left unattended

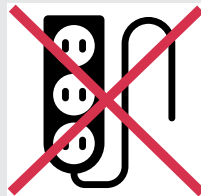

If an extension lead may become overloaded



Where the power cable may be damaged



On a slope or uneven surface



Where there is risk of fire or close to a naked flame



Where it may be damaged by chemicals



Where there is a risk of interference by foreign objects



This product is not made for DIY repair



If there is a risk of water falling on the unit

Specification

Model no.	DCP16C
Colour	White/Black
Power supply	220-240V~, 50Hz
Operating temperature	5-43°C
Thermostat range	17-30°C
Rated Input Power	1.8kW
Cooling Capacity	4.5kW
Dehumidification Capacity	70L/day
Noise Level Minimum (Lo)	68dB(A)
Noise Level Maximum (Hi)	70dB(A)
Air Volume (Hi/Med/Lo)	440/370/290
Refrigerant	R410A
Fan speeds	3
Modes	Sleep/Dry/Cool/Turbo
Timer	24 hours
Dimensions (w x d x h)	530 x 345 x 840mm
Min room size	21m ²
Max room size	34m ²
Weight net	34kg
Weight gross	38kg

- For greater precision, please always refer to the rating label placed on the product.

Parts

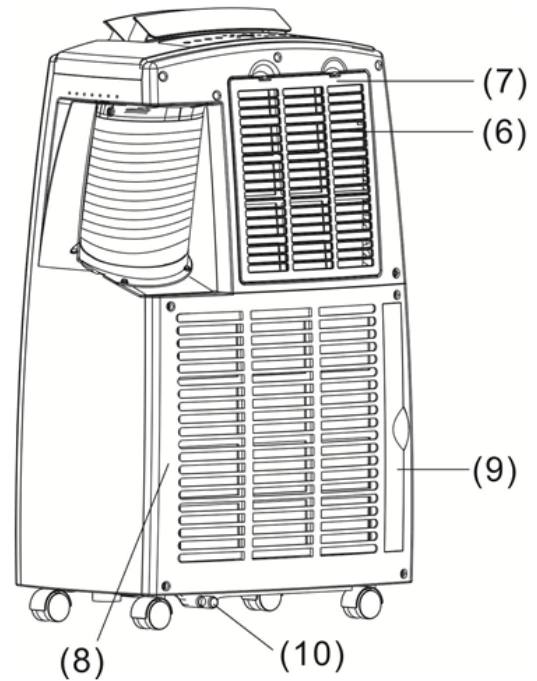
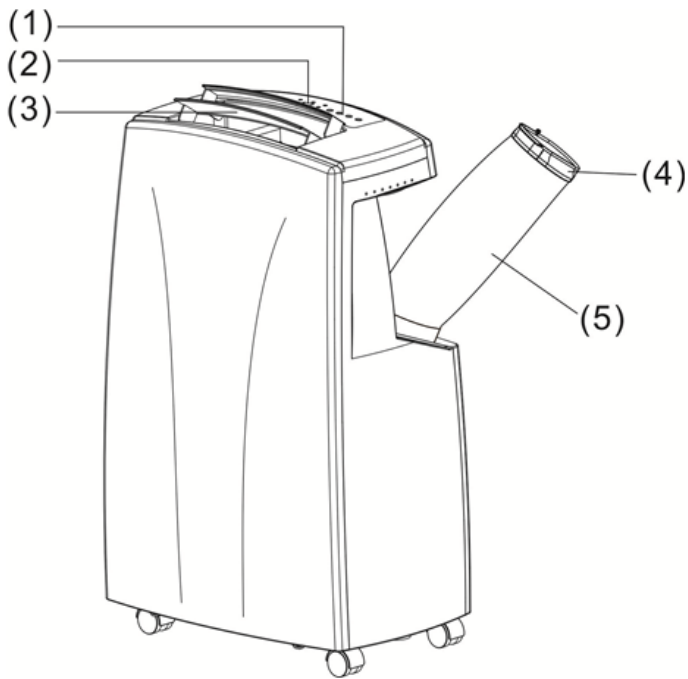

- (1) Control panel
- (2) Display screen
- (3) Air outlet & adjustable louvres
- (4) Window kit adaptor
- (5) Exhaust hose

- (6) Cool air inlet
- (7) Cool air filter
- (8) Hot air inlet
- (9) Hot air filter
- (10) Drain plug (please fit before use)

1 x Exhaust hose

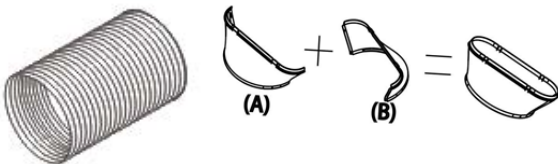

1 x Window slider kit (with hole)

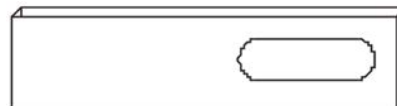

1 x Remote control

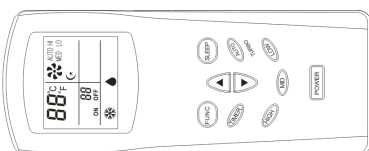

1 x Window slider kit (without hole)



Control Panel

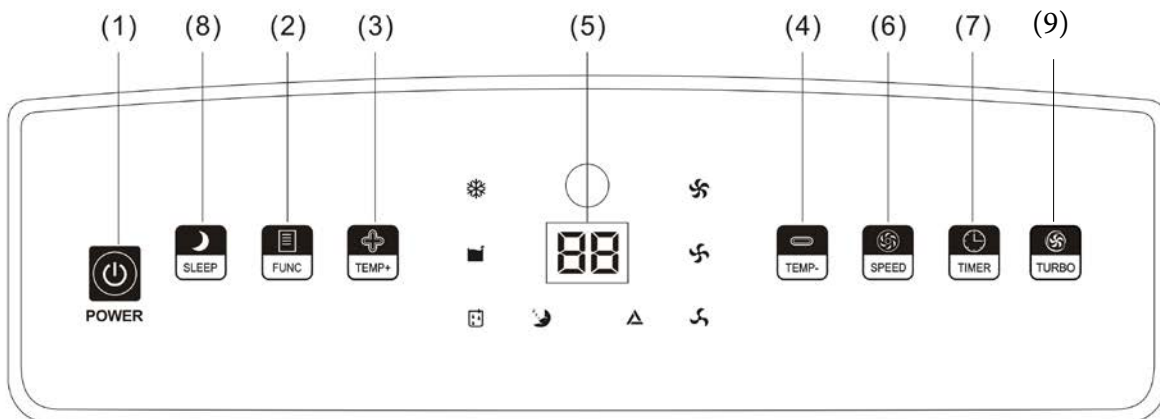

- | | |
|------------------------------|------------------|
| (1) Power button | (6) Speed button |
| (2) Function button | (7) Timer button |
| (3) Temp increase (+) button | (8) Sleep button |
| (4) Temp decrease (-) button | (9) Turbo button |
| (5) LED display screen | |

Indicator Lights

In order - counter clockwise:

- Cool mode
- Tank full
- Dry (dehum) mode
- Sleep mode
- Auto mode
- Low fan speed
- Med fan speed
- High fan speed



LED Display

- The LED display indicates the current set temperature or the timer setting.
- When the set temperature or the timer is adjusted, the new setting is shown on the display.
- The LED display is also used to show error codes should a fault occur.

PREPARATION

NOTE: All the illustrations in the manual are for explanation purpose only. Your machine may be slightly different. The unit can be controlled by the control panel or with the remote control.

EXHAUST HOSE INSTALLATION

The exhaust hose and adaptor must be installed or removed in accordance with the set function (**FUNC**). For **COOL & DRY** functions, the exhaust hose must be installed. For **FAN** only - the exhaust hose should be removed.

EXHAUSTING HOT AIR

In **COOL** function the appliance must be placed close to a window or opening so the warm exhaust air can be expelled outside.

CHOOSING THE RIGHT LOCATION

Your installation location should meet the following requirements:

- Make sure that you install your unit on an even surface to minimize noise and vibration.
- The unit must be installed near a sufficient power outlet, and if using a continuous drainage method, then the plug areas should be accessible.
- The unit should be located at least 40cm from the nearest wall to ensure proper air circulation. The horizontal louvre blade should be at least 50cm away from obstacles.
- The exhaust hose can be extended, however it's best to keep it to the minimum length required. Ensure the hose doesn't have any sharp bends, sagging areas or kinks
- **DO NOT** cover the Intakes, outlets or remote control signal receptor of the unit, as this could cause damage to the unit.

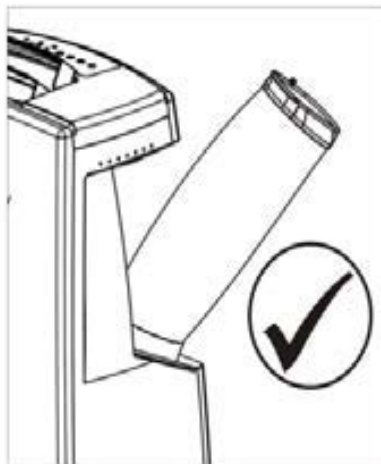
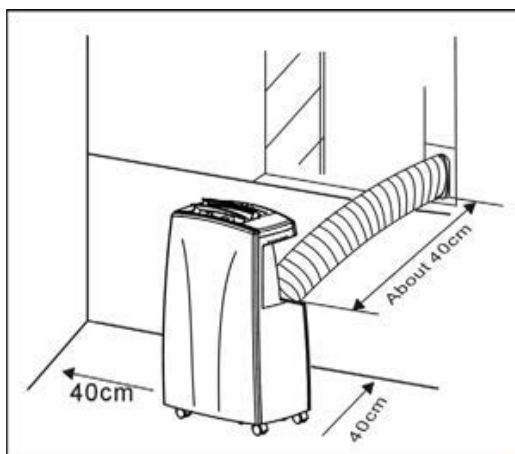

EXHAUST HOSE INSTALLATION

1. To remove the exhaust hose, press slightly & pull away from the unit. The following diagrams indicate the removal of the exhaust hose.
2. If the exhaust hose is loose, twist the tube clockwise to tighten at the base.

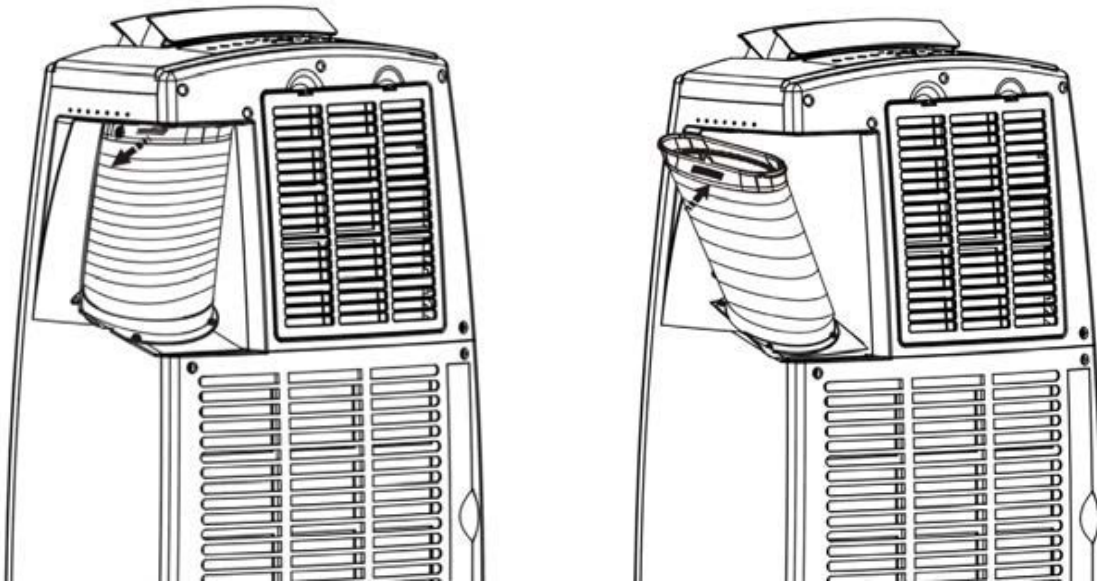

NOTE: This unit has a self evaporative system which removes excess condensation by means of evaporating water collected in the tank. Therefore saving you the hassle of having to use a drip tray or drainage hose. Please make sure the rubber cap is locked into position to avoid any leakage.

NOTE: In high humidity areas, there may be excess water condensation produced that cannot be removed or evaporated. In this instance, the unit will need to be drained. View the WATER DRAINAGE section for details. The unit will automatically switch OFF when the internal water tank is full.

WINDOW KIT INSTALLATION

The window slider kit has been designed to fit most standard vertical and horizontal window applications, however it may be necessary for you to modify some aspects of the installation procedures for certain types of windows. The window slider kit can be fastened with screws (not supplied) if required.

Refer to Fig. 1 & Fig. 2 below:

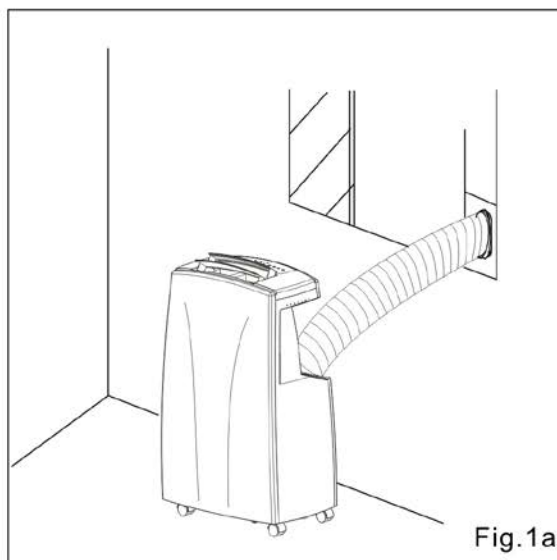
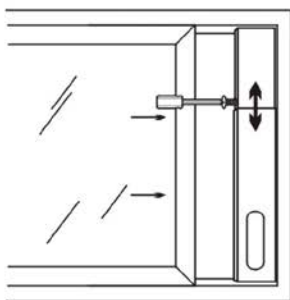
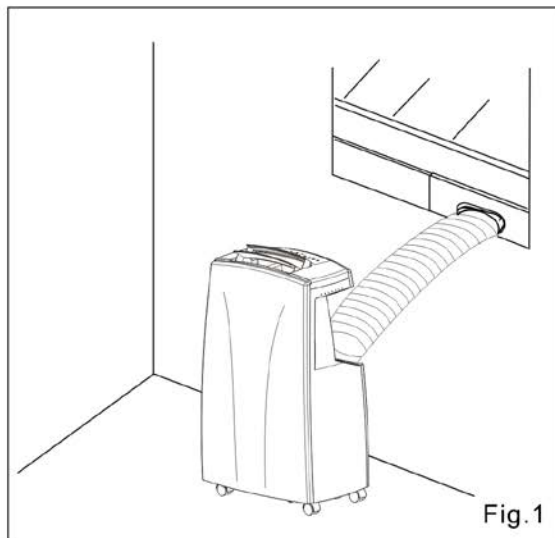
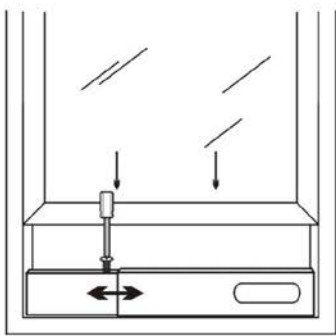

POWER

Press the **POWER** button to turn the unit **ON** or **OFF**.

FUNCTION

Press the **FUNC** button to select between **COOL**, or **DRY** modes.

COOLING MODE

1. The exhaust hose needs to be installed for this mode.
2. To set this mode, press the **FUNC** button until the **COOL** indicator light illuminates on the control panel.
3. Set the target temperature between 17-30°C by pressing the increase **(+)** or decrease **(-)** buttons until the desired temperature is displayed on the LED display.

TIP: The most suitable temperature setting for a room during summer is 24°C.

DRY (DEHUM) MODE

1. The exhaust hose & rubber cap needs to be removed for this mode, and a drain hose (not supplied) should be attached to the drainage hole.
2. To set this mode, press the **FUNC** button until the **DRY** indicator light illuminates on the control panel.
3. The fan speed is selected automatically by the unit and cannot be changed.

NOTE: Keep windows and doors closed for the best dehumidifying effect.

TEMP+ / TEMP-

Press the **TEMP+** button to increase the set temperature or press the **TEMP-** button to decrease the set temperature. The temperature can be set between 17-30°C.

NOTE: The time taken to reach the set temperature will depend on the environment and the size of the space in which the unit is operating in. For example, if the ambient temperature is too hot or the room is too large, the rate at which the temperature descends will be slow as the cooling may be less effective.

FAN SPEED

1. The exhaust hose needs to be removed for this mode.
2. Press the **SPEED** button to select either LOW, MEDIUM, HIGH or AUTO fan speeds. If AUTO fan speed is selected, the unit operates at maximum capacity and HIGH fan speed while the room temperature is more than 2°C from the set temperature. When the room temperature is within 2°C of the set temperature, the unit operates at MEDIUM fan speed. Once the room temperature reaches the set temperature, the unit will operate at LOW fan speed to efficiently maintain the desired temperature.
3. When HIGH, MEDIUM or LOW speed is selected, the unit operates at maximum capacity until the set temperature is reached. The fan operates at the selected speed.

TURBO

If **TURBO** mode is selected, the unit will operate at the highest speed for 30 minutes before changing to AUTO mode. Press the TURBO or FAN SPEED button to cancel this function at any time. If the unit is in TURBO mode, the AUTO icon will be flashing.

NOTE: TURBO mode can only be selected from the control panel.

SETTING THE TIMER

A timer can be set to automatically turn the appliance **ON** or automatically turn it **OFF**.

To set the unit to automatically turn ON, follow the below instructions:

1. While the unit is **OFF** press the **TIMER** button to set the desired time. The timer can be set in 1 hour increments up to 24 hours.
2. After the **TIMER** has been set, choose what settings you'd like the unit to operate in.
3. If the **POWER** button is pressed after completing the above, the timer will be cancelled.

To set the unit to automatically turn OFF, follow the below instructions:

1. While the unit is running, press the **TIMER** button and set the desired time (between 1-24 hours) for the unit to remain ON, before automatically turning OFF.
2. If the **POWER** button is pressed before the **TIMER** is up, it will cancel any **TIMER** set.

SLEEP MODE

- The **SLEEP MODE** maintains the optimum room temperature without excessive fluctuations in either temperature or humidity and with quieter operation.
- Press the **SLEEP** button to select the sleep comfort mode. When the unit is in COOLING mode and SLEEP mode is selected, the unit will increase the set temperature 1°C each hour to a maximum of 2°C over two hours. These temperatures will be maintained for the remainder of the time set to help maximize sleep comfort.
- When setting the SLEEP mode please ensure you set the number of hours required by pressing the TIMER button. The hours set will be shown on the display by pressing either the TEMP+ or TEMP- buttons.

NOTE: This function cannot be used in dehumidifying mode.

- The screen will be blank after 15 minutes of operation, but can be re-activated when any key is pressed.

SWING FUNCTION

This unit does not have an automatic-swing function. Please adjust the Horizontal & Vertical louvres by hand until they are in the desired position.

NOTE: The unit must be **OFF** and disconnected from the power outlet when adjusting the louvres.

Error Codes

ERROR CODES

E1 - Indicates open circuit or short circuit in temperature sensor and PCB.

E2 - Indicates open circuit or short circuit in temperature sensor, copper tube and PCB.

E4 - Indicates the internal water container is full. Refer to the Water Drainage section below.

Overheat Protection - This unit is fitted with an overheat prevention device. If the unit overheats it will automatically turn OFF. The unit can be restarted after 30 minutes.

Water Drainage

WATER DRAINAGE METHOD

When there is excess water condensation inside the unit, the unit will stop running and the tank full error code "**E4**" will show on the LED display. This indicates that the water needs to be drained using the following procedure:





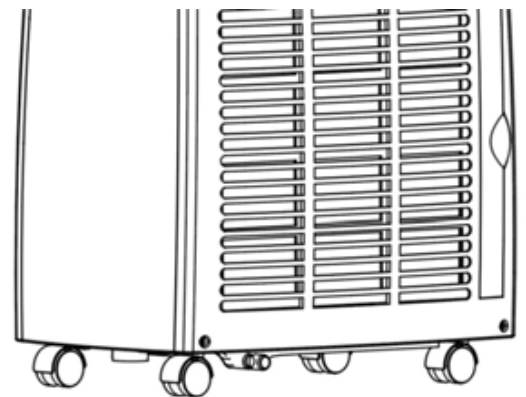



Manual Drainage:

1. Switch off and unplug the unit.
2. Move the unit to a suitable location to drain the water. Consider placing a tray or suitable container under the outlet to catch any water.
3. Remove the drain plug (10) refer to parts illustration.
4. Slightly tilt the unit to the rear and drain the water out.
5. Replace the drain plug before next use.



Remote Control

The remote control can be used to perform all functions. Refer to the below diagram and table.

Icon	Function
	Cooling
	Dehumidifying
	Sleeping
	Timer ON/OFF
	Temperature
	Automatic air flow speed
	High speed
	Medium speed
	Low speed

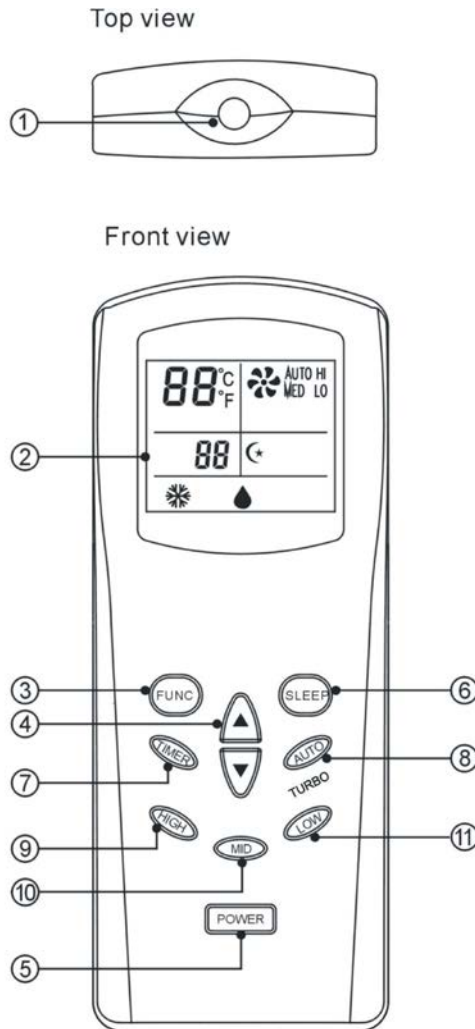

1. Transmitter
2. Display screen
3. Function button
4. Temp increase/decrease buttons
5. Power button
6. Sleep mode button
7. Timer button
8. Auto mode button
9. High speed button
10. Medium speed button
11. Low speed button

Remote Control

Using the Remote Control

1. Open the battery cover of the remote control, and insert 2 x AAA batteries.
2. Please point to the receiver and be within 5m when using the remote control.
3. If the battery voltage is low, please open the battery cover as per the diagram and replace with a new batteries (2 x AAA). Then replace the battery cover.

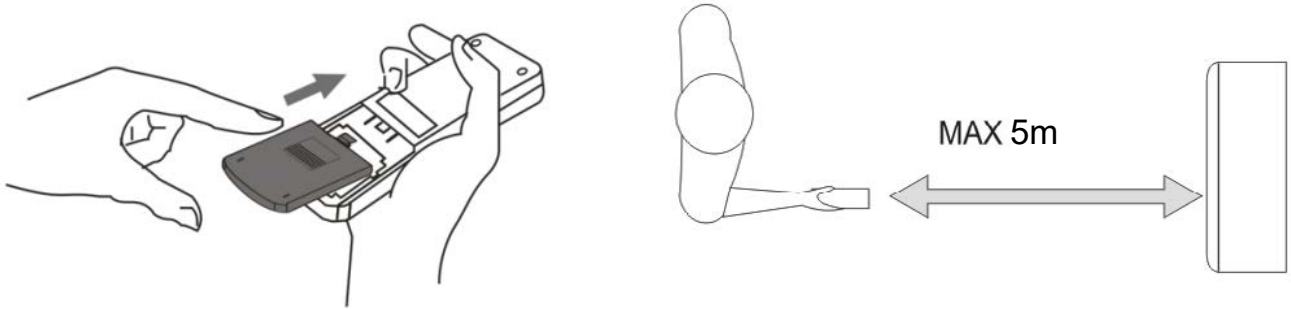

NOTE:

- If the remote control unit is replaced or disposed of, the batteries must be removed and discarded in accordance with current legislation as they are harmful to the environment.
- Do not mix old and new batteries. Do not mix alkaline, standard (carbon-zinc) or rechargeable (nickel-cadmium) batteries.
- Do not dispose of batteries in fire. Batteries may explode or leak.
- If the remote control is not to be used for an extended period of time, remove the batteries.

SAFETY PRECAUTIONS

- Always unplug the unit before cleaning or servicing.
- **DO NOT** use flammable liquids or chemicals to clean the unit.
- **DO NOT** wash the unit under running water. Doing so causes electrical danger.
- **DO NOT** operate the machine if the power supply was damaged during cleaning. A damaged power cord must be replaced with a new cord from the manufacturer.

AIR FILTERS

CAUTION: Never operate the unit without a filter in place.

- Be sure to clean the air filter every week of operation for optimal performance.
- The water collection tray should be drained immediately after "**E4**" error occurs, and before storage to prevent mold.
- In households with animals, you will have to periodically wipe down the grill to prevent blocked airflow due to animal hair.

Following the below diagram, remove the filters from the back of the unit. Use a vacuum cleaner to remove dust from the filter. If further cleaning is required, the filter can be washed in lukewarm water (never hotter than 40 degrees). Ensure it is left to dry completely before reinstalling.

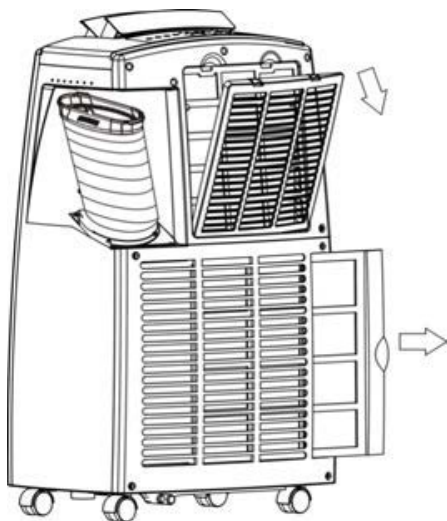

Outside Cabinet

1. Remove any dust build up with a soft brush.
2. Wipe the surface of the unit with a soft damp cloth. Mild detergent can be used for any stubborn marks.

Do not use abrasive sponges, scouring pads, or a stiff brush to clean the unit.

IMPORTANT

The control panel and other parts must not come into contact with water or any other liquids.

Maintenance

Storage

If not using the unit for an extended period of time, after cleaning please:

- Turn the unit **OFF**, unplug and take care of the mains lead & plug.
- Drain any water from the unit according to the instructions in the following sections.
- Run the appliance on **FAN MODE** for 12 hours in a warm room to dry out and prevent mould.
- Clean the air filter as described on the previous page.
- Remove the batteries from the remote control.
- Cover the unit and store it upright in a location where it will not receive direct sunlight.
NB- Prolonged exposure to direct sunlight will discolour the enclosure.

If the unit fails to operate efficiently, is broken or other problems arise, unplug and do not operate. Ask for advice by calling your local after sales service agent or the Customer Care Centre on 1300 556 816 (AU) / 0800 666 2824 (NZ).

Warranty

Please refer to the warranty card in the box for warranty information. For any troubleshooting advice, please contact the relative Customer Care Centre below.

Glen Dimplex Australia Pty Ltd

1340 Ferntree Gully Road,
Scoresby 3179, Victoria
Australia
Ph: 1300 556 816

Glen Dimplex New Zealand Ltd

38 Harris Road, East Tamaki,
Auckland 2013
New Zealand
Ph: 0800 666 2824

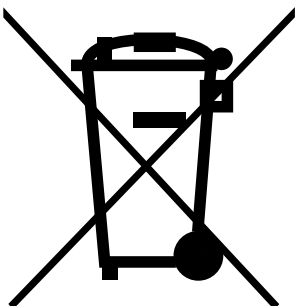

Recycling: Do not dispose of electrical appliances as unsorted municipal waste. Use separate collection facilities. Contact your local government for information regarding the collection systems available. If electrical appliances are disposed of in landfills or dumps, hazardous substances can leak into the ground water, polluting the food chain and damaging health and well-being.



Customer Care: 1300 556 816
customer.care@glendimplex.com.au
www.dimplex.com.au

Supplied by Glen Dimplex Australia
1340 Ferntree Gully Road, Scoresby, Victoria, 3179

© Glen Dimplex Australia. All rights reserved. Material contained in this publication may not be reproduced in whole or in part, without prior permission in writing of Glen Dimplex Australia.