

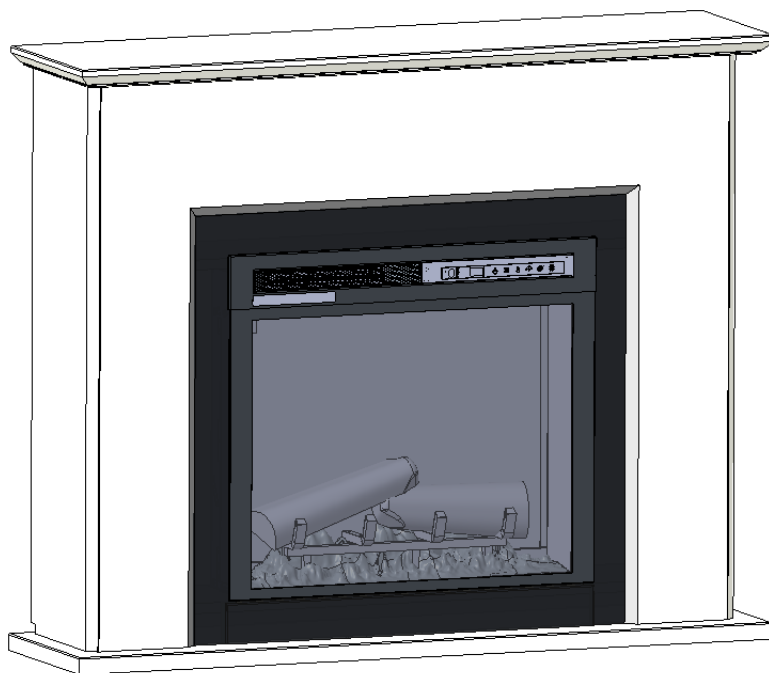

INSTRUCTION MANUAL



Beading 1.5kW Electric Fire Suite

Model: BDG15-AU

For domestic household use only.



IMPORTANT

THESE INSTRUCTIONS SHOULD BE READ CAREFULLY AND RETAINED FOR FUTURE REFERENCE.

CAUTION: FAILURE TO FOLLOW THESE INSTRUCTIONS MAY CAUSE INJURY AND/OR DAMAGE AND MAY INVALIDATE YOUR WARRANTY

Please read the operating instructions carefully before using your product for the first time and keep them in a safe place.

- When using electrical appliances, basic precautions should always be followed to reduce the risk of fire, electrical shock and injury to persons, including the following:
- If the appliance is damaged, check with the supplier before installation and operation.
 - Do not use outdoors.
 - Do not use in the immediate surroundings of a bath, shower or a swimming pool.
 - Do not use this heater if it has been dropped.
 - Do not use if there are visible signs of damage to the heater.
 - Use this heater on a horizontal and stable surface, or fix it to the wall, as applicable.
- Do not locate the appliance immediately below a fixed socket outlet or connection box.
- This appliance is not intended for use by persons (including children) with reduced physical, sensory or mental capabilities, or lack of experience and knowledge, unless they have been given supervision or instruction concerning use of the appliance by a person responsible for their safety.
- Children should be supervised to ensure that they do not play with the appliance.
- Do not use this appliance in series with a thermal control, a program controller, a timer or any other device that switches on the heat automatically, since a fire risk exists when the appliance is accidentally covered or dis-placed.
- In the event of a fault, unplug the appliance.
- Unplug the appliance when not required for long periods.
- This product is only intended for **INDOOR RESIDENTIAL** applications only.
- **DO NOT** cover cord with carpeting, throw rugs, runners, or similar coverings.
- **DO NOT** route cord under furniture or appliances. Take care to position the cord away from traffic areas and where it will not be a tripping hazard.
- This appliance must not be used in a bathroom.
- Although this appliance complies with safety standards, we do not recommend

its use on deep pile carpets or on long hair type of rugs

- The appliance must be positioned so that the plug is accessible.
- If the supply cord is damaged it must be replaced by the manufacturer or service agent or a similarly qualified person in order to avoid a hazard.
- Keep the supply cord away from the front of the appliance.
- Do not use this heater in small rooms when they are occupied by persons not capable of leaving the room on their own, unless constant supervision is provided.
- To reduce the risk of fire, keep textiles, curtains and or flammable material a minimum distance of 1m from the air outlet.
- In order to avoid overheating, **DO NOT COVER** the appliance. Do not place material or garments on the appliance, or obstruct the air circulation around the appliance, for instance by curtains or furniture, as this could cause overheating and a fire risk.
-  This Heater carries the warning symbol indicating that it must not be covered.
- In order to avoid a hazard due to inadvertent resetting of the thermal cut-out, this appliance must not be supplied through an external switching device, such as a timer, or connected to a circuit that is regularly switched on and off by the utility.
- **CAUTION** Some parts of this product can become very hot and cause burns. Particular attention has to be given where children and vulnerable people are present.
- Children shall not turn on/off the appliance.
- Ensure that furniture, curtains or other combustible material are positioned no closer than 1 metre from the appliance.
- Unplug the appliance when not required for long periods.
- Keep the supply cord away from the front of the appliance.

WARNING: KEEP BATTERIES OUT OF REACH OF CHILDREN

- Swallowing may lead to serious injury in as little as 2 hours or death, due to chemical burns and potential perforation of the oesophagus.
- If you suspect your child has swallowed or inserted a button battery immediately call the 24-hour Poisons Information Centre on 13 11 26 (in Australia) or 0800 764 766 (in New Zealand) for fast, expert advice.
- Examine devices and make sure the battery compartment is correctly secured, e.g. that the screw or other mechanical fastener is tightened. Do not use if the compartment is not secure.
- Dispose of used button batteries immediately and safely. Flat batteries can still be dangerous.

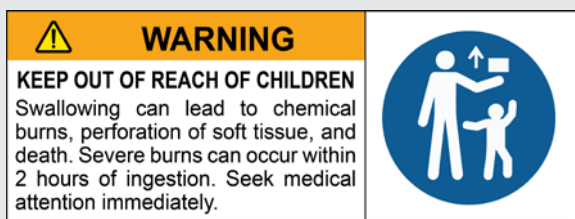

CAUTION: No obvious symptoms

Unfortunately, it is not obvious when a button or coin battery is stuck in a child's oesophagus (food pipe).

There are no specific symptoms associated with this. The child might:

- cough, gag or drool a lot
- appear to have a stomach upset or virus
- be sick
- point to their throat or stomach
- have a pain in their abdomen, chest or throat
- be tired or lethargic
- be quieter or more clingy than usual or otherwise 'not themselves'
- lose their appetite or have a reduced appetite
- not want to eat solid food/be unable to eat solid food

These types of symptoms vary or fluctuate, with the pain increasing and then subsiding.

A specific symptom to button and coin battery ingestion is vomiting fresh (bright red) blood. If the child does this seek immediate help. The lack of clear symptoms is why it is important to be vigilant with 'flat' or spare button or coin batteries in the home and the products that contain them.

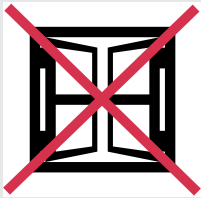

Exposed to the weather outdoors



Near water

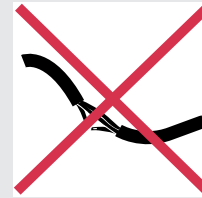

If the power cable wires are frayed or cut



Where small children may be left unattended

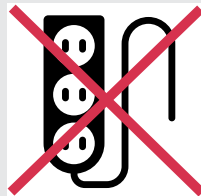

No extension leads or power boards



Where the power cable may be damaged



On a slope or uneven surface



Where there is risk of fire or close to a naked flame



Where it may be damaged by chemicals



Where there is a risk of interference by foreign objects



This product is not made for DIY repair



If there is a risk of water falling on the unit

Specifications

Model no.	BDG15-AU
Colour/Finish	Matte White - RAL9016
Firebox	XHD23L-AU
Watts	1400-1500
Heat Settings	1
Thermostat Control	Yes
Remote Control	Yes
Warranty	2 years
Dimensions (w x d x h)	1100 x 280 x 900mm

For greater precision, please always refer to the rating label placed on the product.

Setup & Product Dimensions

⚠ WARNING: FALLING OR TIPPING APPLIANCES CAN CAUSE INJURY OR DEATH OF YOUNG CHILDREN, PLEASE ENSURE CHILDREN DO NOT CLIMB, HANG OR STAND ON THIS PRODUCT.

⚠ WARNING: THE APPLIANCE IS PROVIDED WITH A TIPPING RESTRAINT, THIS RESTRAINT IS NOT A SUBSTITUTE FOR PROPER ADULT SUPERVISION. THIS RESTRAINT MAY PROVIDE PROTECTION AGAINST TIPPING FURNITURE. DO NOT ALLOW CHILDREN TO CLIMB ON FURNITURE. FAILURE TO DETACH THIS RESTRAINT BEFORE MOVING FURNITURE MAY RESULT IN INJURY AND DAMAGE.

Tipping Restraint Kit

This product is provided with a 'Tipping Restraint Kit' as shown below. This prevents the product from accidentally tipping. Instructions are supplied with this kit please follow these instructions carefully. This accessory is intended to improve the safety of the product.

Thermal Safety Cut-out

The built-in overheat cut-out, switches off the appliance automatically in the event of a fault! Should this occur switch off the appliance or disconnect the mains plug from the socket.

Remove any obstructions which may have caused the overheating. After a short cooling down phase, the appliance is ready for use again! If the fault should occur again, contact your local dealer!

WARNING: In order to avoid a hazard due to inadvertent resetting of the thermal cut-out, this appliance must not be supplied through an external switching device, such as a timer, or connected to a circuit that is regularly switched on and off by the utility.

Tipping restraint kit

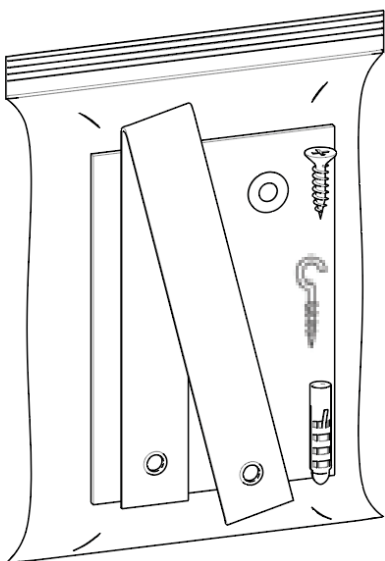

Setup & Product Dimensions

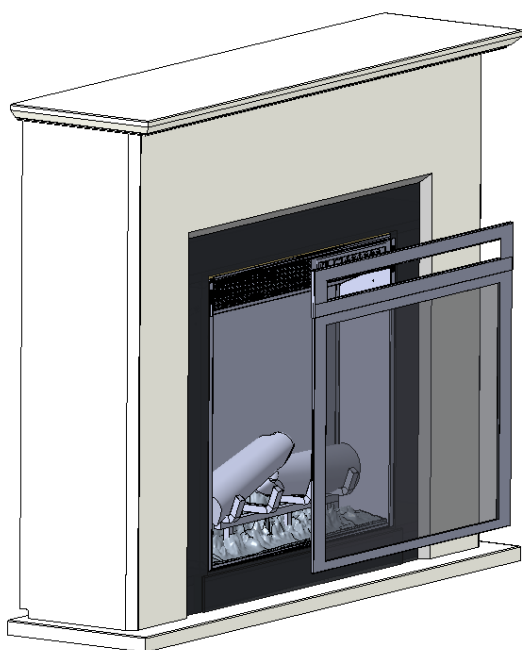
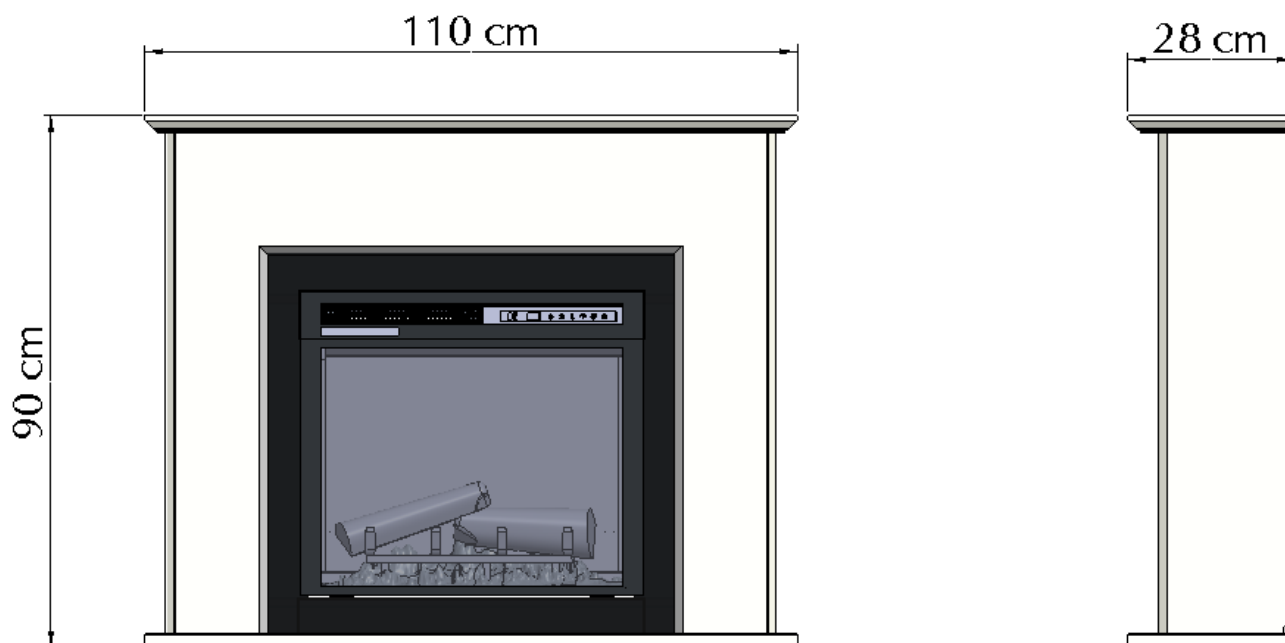

Mounting Glass frame- See Fig to the left. Product comes with a glass frame that is not fixed to firebox, but packed separately to the fire in its own packing.

To fix the frame the hooks on both side at the top need to be aligned up with corresponding slots on both sides of the fire.

When hooked in place the frame hangs vertical covering the fire.

Light Emitting Diode

This fire is fitted with LED (Light Emitting Diode) lamps. These LED lamps are maintenance-free and should not require replacing during the life of the product.

Touch Panel & Remote

WARNING: The Electric Firebox must be installed properly before it is used.

CAUTION: Except for installation and cleaning described in this manual, an authorized service representative should perform any other servicing. The manual controls for the Electric Firebox are located on the front panel. Touch an icon to activate. The selected setting displays on the left side of the panel.

A multi-function remote control is also provided. The remote control has a range of approximately 9m. To operate correctly, the remote control must be pointed toward the front of the electric firebox. **Note:** It takes time for the receiver to respond to the transmitter.

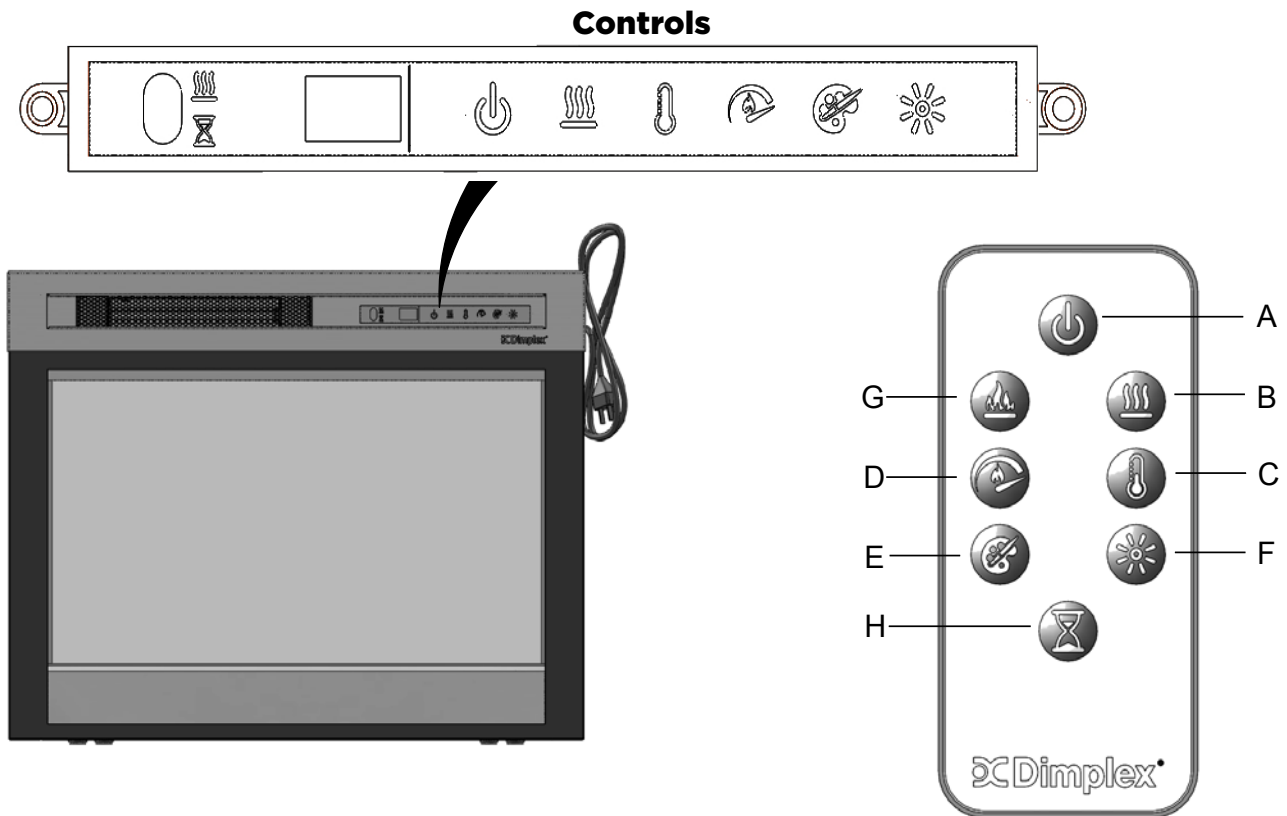



Activating the remote control:

1. To activate the remote control remove the clear battery isolation strip at the base of the remote control, which is used to ensure your remote control reaches you fully charged.





To replace the battery:

1. Remove the screw, push down on the battery cover located on the back of the remote control. Slide the battery cover open.
2. Install 1 x 3V CR2025 Lithium battery in the battery holder. The positive (+) side of the battery faces up.
3. Close the battery cover and replace the screw

Operation

	Icon	Function	Description
A		Power	<p>Press to turn unit Off or On.</p> <p>Unit Off Press to turn everything Off. Press again to turn unit On with previous settings.</p> <p>Unit On Press to turn unit On with previous settings.</p> <ul style="list-style-type: none"> - If the flame effect was On, the flame will turn on and the previous heat setting will be activated (On or Off). Display will show current heater temperature setting and after 2 sec displays the room temperature. - [remote only] If the flame effect was Off, the previous heat setting will be activated (On or Off). - [panel only] If the flame effect was Off, the flame will turn on and the previous heat setting will be activated (On or Off)
B		Heat	<p>Heat On Press to turn heat On (indicated by 1 short beep). Display will show current heater temperature setting and after 2 sec displays room temperature. Use the Temp icon to change the heater temperature setting.</p> <p>Heat Off Press to turn heat Off (indicated by 1 short beep).</p> <p>NOTE: After the heater is switched off, the fan will continue on for 60 seconds before turning off.</p>
C		Temp	Press multiple times to raise the heater temperature in 1°C increments. Display will show current temperature. Temperature range is 17°-26° C. This feature is active whenever the heat is enabled.
D		Flame Speed	Press multiple times to toggle through flame speeds (minimum, medium, maximum). Display will show current speed number (F1, F2, F3 respectively).
E		Color Theme	<p>Press multiple times to change the media and flame base colors. This feature is active only when the flame effect is On. Display will show theme (t0, t1, t2, etc.)</p> <p>XHD28L, XHD26L or XHD23L (Log Unit) themes:</p> <ul style="list-style-type: none"> • Theme t0 - no flame • Theme t1 - Natural (flame base off) • Theme t2 - Red Highlights (flame base red/orange) • Theme t3 - Blue Highlights (flame base blue)
F		Brightness	<p>Press to change the flame and logs brightness. Display will show b3, b1, b2 respectively.</p> <ul style="list-style-type: none"> • High • Low • Medium
G		Flame	Press to turn the flame effect On. Press again to turn the flame effect Off.
H		Timer	Press multiple times to change the sleep timer by 0.5 hr from 0.5 hr to 8 hr before turning off. Press again, the remaining time on the timer displays.

User Modes:

Mode Name / Description	Action (Actions cannot be input by remote control)
Change Celsius (°C) to Fahrenheit (°F)	Press both Temp Button () and flame speed() on the unit and hold until beep is heard and display flashes. (To revert back to Celsius repeat this action)
Disable / Enable Heat Options	Hold both Heat Button () and Temp Button (), on the unit, for 2 seconds, when the heater has been disabled the display will read "--" and beep. To enable heat repeat this action.

Resetting the Temperature Cut off Switch

Should the heater overheat, an automatic cut out will turn the heater off and it will not come back on without being reset. It can be reset by disconnecting power at the main electrical panel and waiting 5 minutes before plugging the unit back in.

CAUTION If you need to continuously reset the heater, unplug the unit and call technical support.

Cleaning

Over time, dust can accumulate which can effect performance. It is recommended to clean the unit at least once a month.

CAUTION: ALWAYS Turn the unit **OFF** and disconnect the appliance from the power supply before undergoing any cleaning and maintenance.

For general cleaning use a soft clean duster – never use abrasive cleaners. The glass viewing screen should be cleaned carefully with a soft cloth.

DO NOT use proprietary glass cleaners.

To remove any accumulation of dust or fluff the soft brush attachment of a vacuum cleaner should occasionally be used to clean the outlet grille of the fan heater.

WARNING: do not operate the product without the grille and outer glass in position as this may effect the operation of the heater.

IMPORTANT

The control panel and other parts must not come into contact with water or any other liquids.

Warranty

Please refer to the warranty card in the box for warranty information. For any troubleshooting advice, please contact the relative Customer Care Centre below.

Glen Dimplex Australia Pty Ltd

8 Lakeview Drive,
Scoresby 3179, Victoria
Australia
Ph: 1300 556 816

Glen Dimplex New Zealand Ltd

38 Harris Road, East Tamaki,
Auckland 2013
New Zealand
Ph: 0800 666 2824



Recycling: Do not dispose of electrical appliances as unsorted municipal waste. Use separate collection facilities. Contact your local government for information regarding the collection systems available. If electrical appliances are disposed of in landfills or dumps, hazardous substances can leak into the ground water, polluting the food chain and damaging health and well-being.



Customer Care: 1300 556 816
customer.care@glendimplex.com.au
www.dimplex.com.au

Supplied by Glen Dimplex Australia
8 Lakeview Drive, Scoresby, Victoria, 3179

© Glen Dimplex Australia. All rights reserved. Material contained in this publication may not be reproduced in whole or in part, without prior permission in writing of Glen Dimplex Australia.

BDG15-AU V3