

Dimplex®

DEHUMIDIFIER 40L

INSTRUCTION MANUAL

GDDEY40

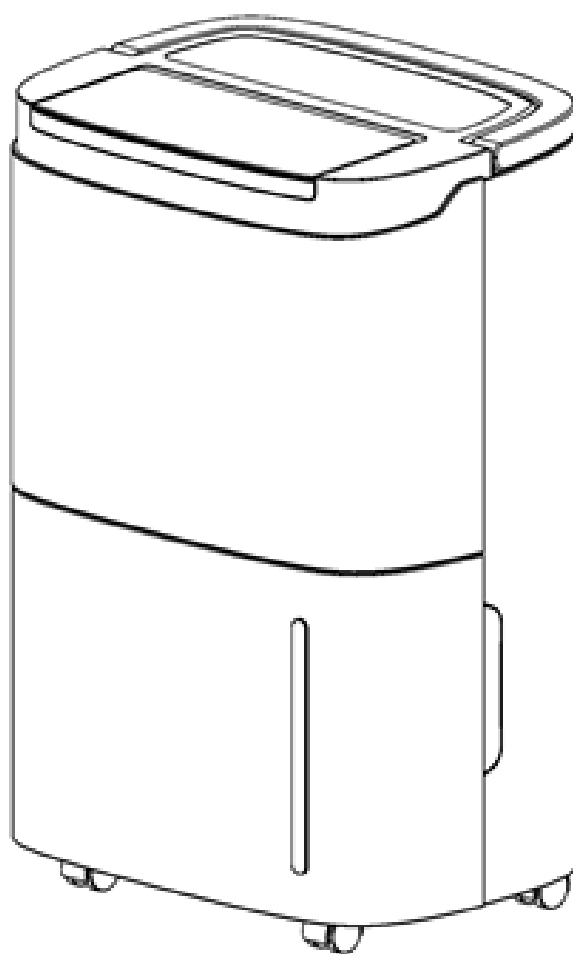

Table of Contents

Safety Warning.....	2
Frequent enquiries	3
Installation... ..	4
Components.....	5
Control Panel.....	6
Operation Methods.....	7
Drainage	8-9
Maintenance	10
Troubleshooting.....	11

TECHNICAL SPECIFICATIONS

Model	GDDEY40
Operating Voltage	220V-240V~50Hz
Dehumidification Capacity	40L/DAY
Rated Power	560W
Net Weight	18.5KG
Refrigerant	R410a
Noise Level	52dB(A)
Operating Temperature	Between 5-32 degrees celcius
Dimensions	378mmw x 615mmh x 266mmh

Safety Warning

For your safety, please read the following contents carefully before using this dehumidifier:

Safety requirements:

- ◆ Place this dehumidifier on a flat, even surface to reduce vibration and noise.
- ◆ Do not place this dehumidifier in water or other liquids.
- ◆ In order to prevent accidents, please do not use this dehumidifier if wires or other connections are damaged.
- ◆ This appliance can be used by children aged from 8 years and above and persons with reduced physical, sensory or mental capabilities or lack of experience and knowledge IF they have been given supervision or instruction concerning use of the appliance in a safe way and understand the hazards involved.
Children should not play with the appliance.
- ◆ Please remove from power source before cleaning.
- ◆ Please use at the specified voltage.
- ◆ This dehumidifier can only be used indoors, please do not use for other purposes.
- ◆ Please do not place heavy objects on this dehumidifier.
- ◆ Please empty water tank to prevent overflow and spill before restarting this dehumidifier.
- ◆ Please do not place on an incline in case that the spilled water damages the dehumidifier.
- ◆ Please do not place waste or hard objects into the dehumidifier in case damage occurs.
- ◆ If the supply cord is damaged, it must be replaced by the manufacturer, their service agent or a similarly qualified person in order to avoid a hazard.
- ◆ When this dehumidifier is not used for a long time, please unplug the electric cord.
- ◆ Power supply of the Dehumidifier shall comply with the safety regulations where it is used and ensure reliable grounding.

Prohibited:

- ▲ Please do not place this dehumidifier close to heating devices (flame or heaters, etc.).
- ▲ Please do not turn on or turn off this dehumidifier by plugging in or pulling out the plug.
- ▲ Do not use insecticide spray or other flammable substances in the vicinity of this dehumidifier.
- ▲ Do not scratch appearance of this dehumidifier with anything sharp.
- ▲ Do not splash oil or water into this dehumidifier.
- ▲ Do not clean this dehumidifier with water, please wipe it with a damp soft cloth.
- ▲ Do not wipe this dehumidifier with chemical solvents such as benzene, gasoline and alcohol, etc. If this dehumidifier is dirty, please wipe with neutral detergent.
- ▲ Please do not incline this dehumidifier over 45° or place this dehumidifier upside down.

Frequently Asked Questions

Q: Why is less water stored in water tank of the dehumidifier in winter?

- In winter, the ambient temperature is lower and air is drier, therefore the dehumidification ability of the dehumidifier is lower - compared to warmer, summer months.

Q: Why isn't the unit working, or has stopped working suddenly?

- Dehumidifier may be full of water or water tank is not installed properly, drain the water in water tank, or check water tank positioning.
- The target humidity level may have been reached. Adjust target humidity level and re-check operation.
- Relative humidity of the room may be outside of operating range (30% - 80%), similarly ambient temperature of room may not be within operating temperature (5-32C).

Q: Why is hot air blown out from air supply outlet?

- This dehumidifier extracts the air in the room, and the dehumidification unit cools the air, the temperature decreases below the condensation point, the air condenses into water drops, which falls into water tank finally, and the dehumidified air is heated by the temperature returning unit. This can reduce energy consumption and also accelerate dehumidification, therefore, hot air is blown out, and this not a fault.

Q: My unit sounds too noisy, is this a fault?

- Some noise is part of normal operation, these units are not completely silent or quiet. A reasonable level of noise should be expected. If you believe this is above average, check the unit is placed on a flat surface to reduce reverberation. You may also like to check the air filter is clean. Adding rubber pads underneath the unit can absorb some residual noise too.

Installation

- ◆ Please drain any water from water tank before running.
- ◆ During running please do not open doors and windows as much as possible, as open doors and windows will increase power usage of the product.
- ◆ When the dehumidifier is installed, a certain space must be reserved around this dehumidifier, the minimum distance above is 50cm, and the minimum distance in front/rear and left/right is 20cm as required, as shown in figure below.

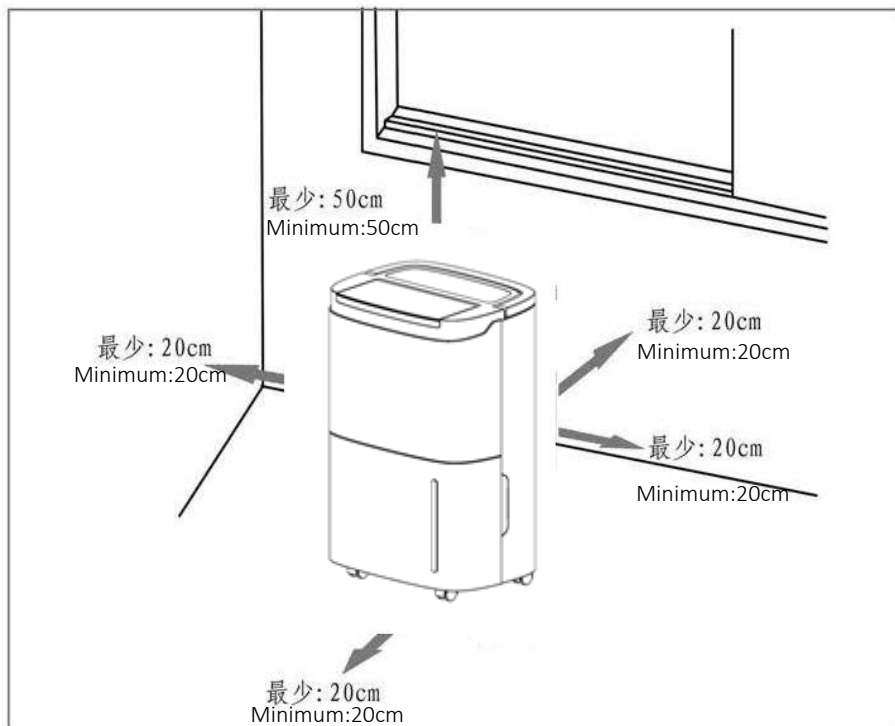

Components

Front side

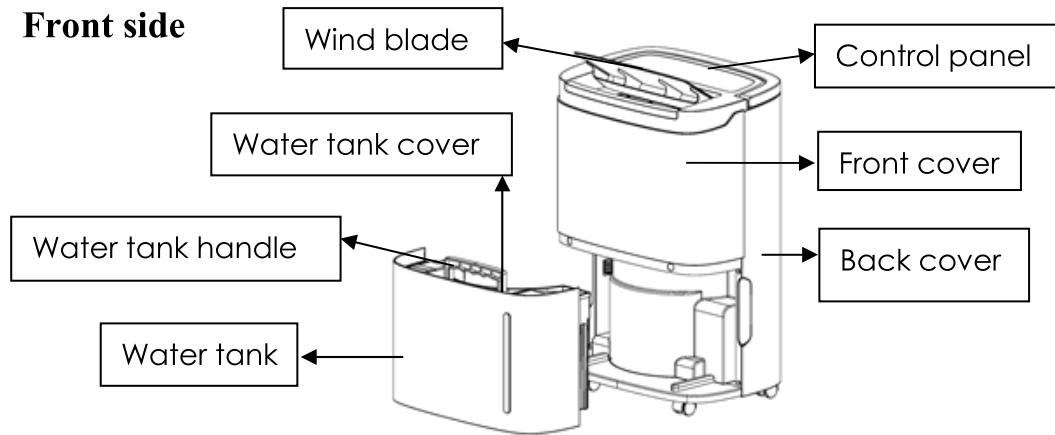

Back side

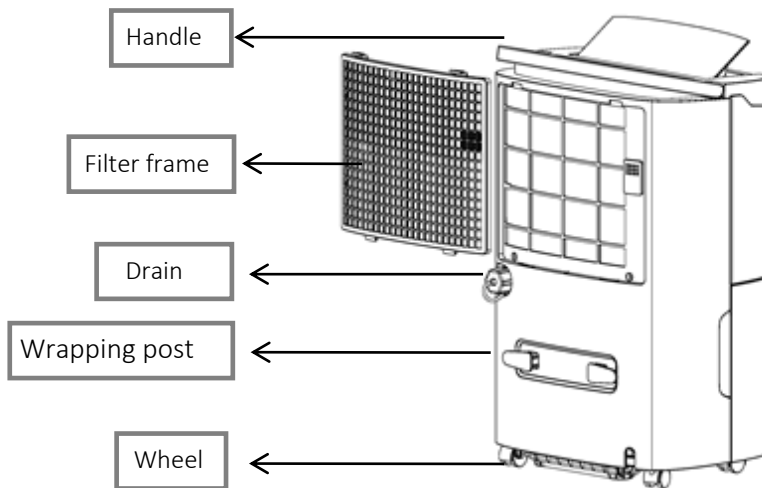

Control panel

Timer

Press this key to set the timer of the dehumidifier (between 1-24 hours). To cancel the timer, press twice continuously after confirmation of setting time.

Inside Drying

Press this key to start the internal drying procedure within the dehumidifier, this can prevent mold inside the dehumidifier due to damp. The whole drying procedure needs approximately 1h.

Air speed

In AUTO or CONTINUOUS mode air speed HIGH or LOW can be selected.

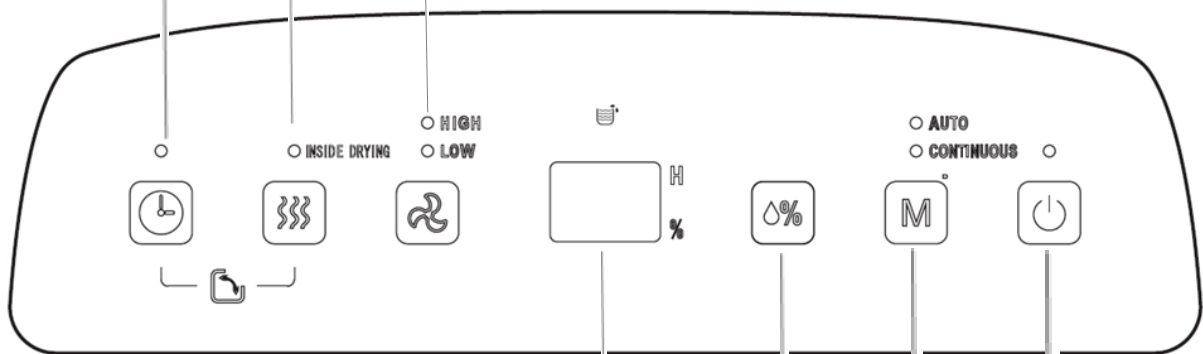

LCD Display

In AUTO, CONTINUOUS AND INSIDE DRYING modes, this figure displays room humidity (% represents percentage of humidity). Display shows the set time in timer state

Humidity setting

Once this key is pressed, the humidity is displayed circularly in the range of 30% - 80% increasing by 5% increments. Note setting a target humidity is only possible while in AUTO mode.

Mode

During startup or timer startup press this key to select AUTO, CONTINUOUS and DRYING modes, etc., and the indicator lamp corresponding to the selected mode is on. Long press (3 seconds) the Mode button to activate the Child Lock. Repeat the process to turn the Child Lock off.

6

On/off key Press this key to turn on or turn off the dehumidifier.

Operating method

Description of functions

Setting the timer

- When the dehumidifier is running, press the [Timer key] to adjust time from 1h to 24h, pressing the key once to increase the setting time by 1h. After the setting time exceeds 24h, the figure returns to 1 to restart cycle. When the set time expires, the dehumidifier turns off automatically. After the setting is selected, if you don't press the timer key again within five seconds, the set time is confirmed.

AUTO mode

- Select AUTO dehumidification, and adjust target humidity percentage. When the ambient humidity of the room is higher than the target the compressor will start and the fan will run at the chosen speed. If the room humidity is lower than the set humidity by -5%, then the compressor will stop but the fan will run at the set speed.
If the ambient air is too dry (i.e. < 40%) you may like to try our 3 in 1 Power Tower (DCEVPT8L). With three functions, the product humidifies, purifies and cools air for ultimate home comfort.

CONTINUOUS (Laundry) mode

- Select CONTINUOUS dehumidification for ongoing dehumidification regardless of relative humidity in the room. This mode is excellent for drying laundry. The compressor is in operation and the fan runs at high speed to aid in drying. Air speed can be regulated via the speed button.

INSIDE DRYING function

- ◆ Press the [Inside Drying key] to start drying within the dehumidifier. Procedure needs approximate 1h:

1. The dehumidifier starts at HIGH air speed and releases air continuously for 30min;
2. The dehumidifier turns to run at LOW air speed and lasts for 20min;

- ◆ How to stop:

1. Press the key again to cancel drying in dehumidifier, and recover to the running state before start of drying.
2. Press the [Power key] to stop drying in dehumidifier and recover to the standby state.

SWING function

To activate the swing louvre, press the Timer button and the Inside Drying button at the same time to start or end the swing function.

Drainage

1. Use of water tank

When the water tank is full of water, the full water icon on LCD flashes (the compressor and fan will stop running), the **BUZZER** sounds for 10 times to remind the user, until the water is drained.

Placing both hands at the side of the back cover, gently remove the water tank and open the tank cover on the right side of the body. Pour the water from the gap between water tank and the cover.



Close the tank cover and rotating water tank handle down, then put the water tank gently and put it back in the right place to restart dehumidifier.



Attention: when the water tank is full of water, please empty it. Before putting the water tank into the dehumidifier, please confirm whether the floater rotates flexibly or not, and then push it in position with both hands.

2. Continuous drainage

If you do not want to drain water in the water tank frequently, you can connect a drainage pipe (with inner diameter 9mm) on the back of this dehumidifier to drain water.

- ◆ Find the position where the water outlet is blocked on the back, as shown in figure below:

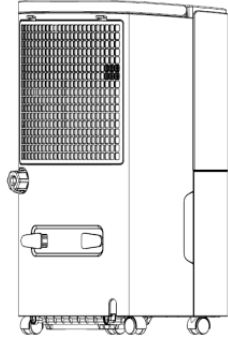

- ◆ Pull down the water plug.

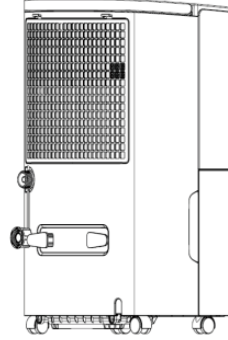

- ◆ Connect a drainage pipe at proper length onto the water outlet.

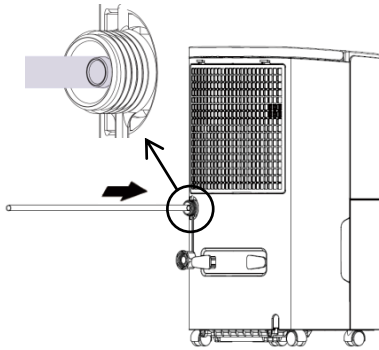

- ◆ Before using please check whether the drainage pipe is connected firmly or not in case that water leaks.

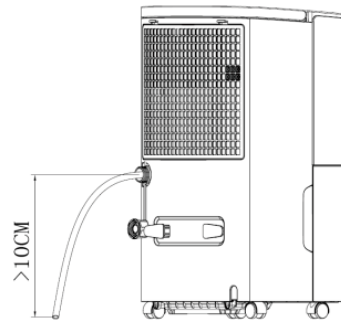

Attention: the level height of externally connected water pipe shall not be higher than the water outlet, and the water pipe at rear-end shall transit smoothly, otherwise, the leakage risk exists since drainage is not smooth.

Maintenance

Precautions:

Please disconnect power supply before maintenance or repair to prevent electric shock.

If the dehumidifier is not used for a long time, please disconnect power supply.

Please do not clean the dehumidifier body with chemical solvents such as alcohol, gasoline and benzene, etc.

Please clean the water tank and its cover with soft cloth dipped in cold or warm water regularly to prevent mould inside the dehumidifier.

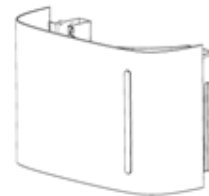

Wipe the surface of the dehumidifier slightly with wet cloth, and do not use detergent or abrasive in case the plastic surface is damaged.



If using frequently, please clean the filter and the frame at least once every two weeks with cold or warm water, do not use chemical solvents or hot water.

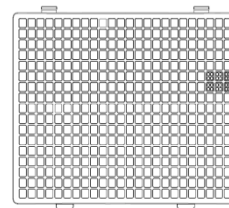

Displayed code	Description
FL	The water tank is full
E1	The coil sensor detects anomaly
E2	The room temperature sensor detects anomaly
P1	The unit is in the defrosting state,normal
CL	The unit is in the internal drying state,normal
LC	Child lock is on

Troubleshooting

If the following problems occur to the dehumidifier the following solutions can be adopted.

Symptoms	Possible reasons	Solutions
The dehumidifier does not run	Is it disconnected from the power?	Reinsert power plug into socket.
	Is the water tank full of water? (or is it placed at incorrect position)	Drain water from the water tank, and then attach the water tank again.
	The ambient temperature is lower than 5°C or higher than 32°C	Unfortunately this device will only operate within the temperature range of 5-32°C
The dehumidification function is not effective	Is the room temperature or humidity too low?	In colder and drier areas the dehumidification ability will be reduced.
	Are the air outlet or inlet blocked?	Clean and recheck operation
Air is not blown out	Is the air filter blocked?	Clean and recheck operation
Noise is abnormal during operation	Is the dehumidifier placed improperly so that it is inclined or unstable?	Please place the dehumidifier on a level surface
	Is the air filter blocked?	Clean and recheck operation
	There is "tittering" sound	The flowing sound of refrigerant, which is a normal phenomenon.
Water leaks	Connection of drainage pipe becomes loose	Fasten drainage pipe.
	Drainage system is blocked	Remove obstacles and straighten out water pipe.
Frosting occurs	The ambient temperature is low, and it is in the state waiting for defrost.	This normal and the dehumidifier has an automatic defrosting function.



Glen Dimplex New Zealand Ltd

38 Harris Road, East Tamaki

Auckland, New Zealand

P.O. Box 58473, Botany

Manukau 2163, New Zealand

Phone: 09 274 8265

Fax: 09 274 8472

Email: sales@glendimplex.co.nz

Web: www.dimplex.co.nz