

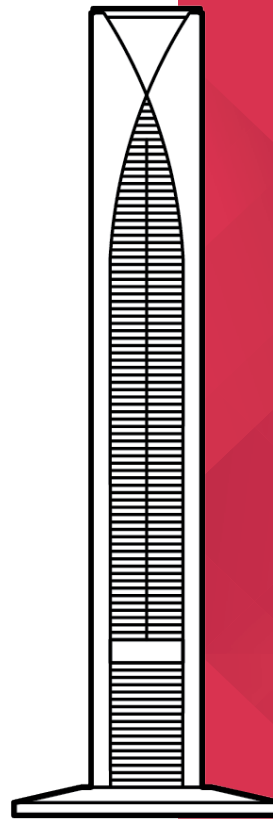

INSTRUCTION MANUAL



LED Tower Fan

Model: DCTFE97

For domestic household use only.



IMPORTANT

THESE INSTRUCTIONS SHOULD BE READ CAREFULLY AND RETAINED FOR FUTURE REFERENCE.

Note also the information presented on the appliance

CAUTION: FAILURE TO FOLLOW THESE INSTRUCTIONS MAY CAUSE INJURY AND/OR DAMAGE AND MAY INVALIDATE YOUR WARRANTY

Please read the operating instructions carefully before using your fan for the first time and keep them in a safe place.

WARNING – This appliance must not be used in a bathroom.

WARNING – Do not use this appliance in the immediate surroundings of a bath, a shower or a swimming pool.

- Never immerse the appliance in water or other liquids.
- Operate this unit only on a firm, flat surface.
- Do not place on soft, unstable or non-horizontal/angled surfaces.
- Never operate the appliance if a cable or connector has been damaged, after appliance malfunction or if the appliance was dropped or is otherwise damaged.
- If the mains lead is damaged it must only be replaced by the manufacturers service agent or a similarly qualified person in order to avoid a hazard.
- Please ask a professional service agent to repair the product. Improper repair may cause danger to users.
- Disconnect the appliance from mains power whenever it is not in use, before relocating it, and before cleaning.
- Operate the appliance only at the voltage specified on the rating label.
- Only connect the unit to a properly installed and easily accessible socket so that you can quickly disconnect the plug if necessary.
- Do not connect this product to the mains using an extension lead.
- This fan is only intended for **INDOOR RESIDENTIAL** applications. This fan should not be used for commercial or industrial or

leisure applications or in small enclosed spaces.

- Never use the mains lead as a carrying strap or pulling lead.
- To avoid a fire or electrocution hazard, **NEVER** put the cord near heat registers, radiator, stoves or heaters.
- **DO NOT** cover cord with carpeting, throw rugs, runners, or similar coverings.
- **DO NOT** route cord under furniture or appliances. Take care to position the cord away from traffic areas and where it will not be a tripping hazard.
- **DO NOT** use the unit near windows or where water collects. Rain and water collection may lead to a risk of fire or electric shock.
- Only operate this appliance with a minimum of 50cm clearance all around i.e. away from walls, furniture and overhanging objects such as curtains or a shelf.
- This appliance is not intended for use by persons (including children) with reduced physical, sensory or mental capabilities, or lack of experience and knowledge, unless they have been given supervision or instruction concerning use of the appliance by a person responsible for their safety.
- Children should be supervised to ensure they do not play with the appliance.
- To prevent spillage, empty the water tank before lifting or relocating the appliance.
- **WARNING:** To avoid danger of suffocation please remove all packaging materials particularly plastic and EPS and keep these away from vulnerable people, children and babies.
- **NEVER** drop or insert any object or fingers into any openings.
- Do not use the appliance in locations where paint, petrol or other flammable liquids are used or stored.
- If the supply cord is damaged, it must be replaced by the manufacturer, its service agent or similarly qualified persons in order to avoid a hazard.
- Do not use bug sprays or other flammable cleansers/vapour sprays on or around the unit.

- Always switch off the unit and take the plug out of the socket:
 - If you are not using the unit
 - Before you clean or carry out maintenance on the unit
 - If a fault occurs
 - In the event of an electrical storm.
- Avoid electromagnetic interference. Keep the unit at least 1 metre away from electrical appliances such as televisions & radios.

WARNING - KEEP BATTERIES OUT OF REACH OF CHILDREN

- Swallowing may lead to serious injury in as little as 2 hours or death, due to chemical burns and potential perforation of the oesophagus.
- If you suspect your child has swallowed or inserted a button battery immediately call the 24-hour Poisons Information Centre on 13 11 26 (in Australia) or 0800 764 766 (in New Zealand) for fast, expert advice.
- Examine devices and make sure the battery compartment is correctly secured, e.g. that the screw or other mechanical fastener is tightened. Do not use if the compartment is not secure.
- Dispose of used button batteries immediately and safely. Flat batteries can still be dangerous.





Exposed to the weather outdoors



Near water



If the power cable wires are frayed or cut



Where small children may be left unattended

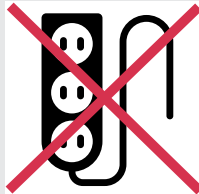

If an extension lead may become overloaded



Where the power cable may be damaged



On a slope or uneven surface



Where there is risk of fire or close to a naked flame



Where it may be damaged by chemicals



Where there is a risk of interference by foreign objects



This product is not made for DIY repair



If there is a risk of water falling on the unit

Specification

Model no.	DCTFE97
Colour	Black
Power supply	220-240V~, 50-60Hz
Rated power	45W
Speed settings	3
Modes	4
Timer	0-12
Air volume	1380m ³ /min
Oscillating	Y
Controls	Touch or remote
Cord storage	Y
Noise level	58dB(A)
Weight (net)	3.4kg
Dimensions (w x d x h)	315 x 315 x 965mm

- For greater precision, please always refer to the rating label placed on the product.

Parts

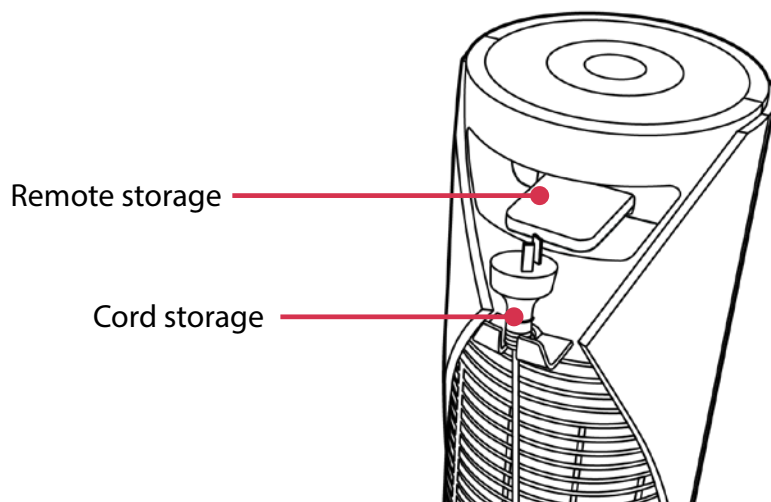
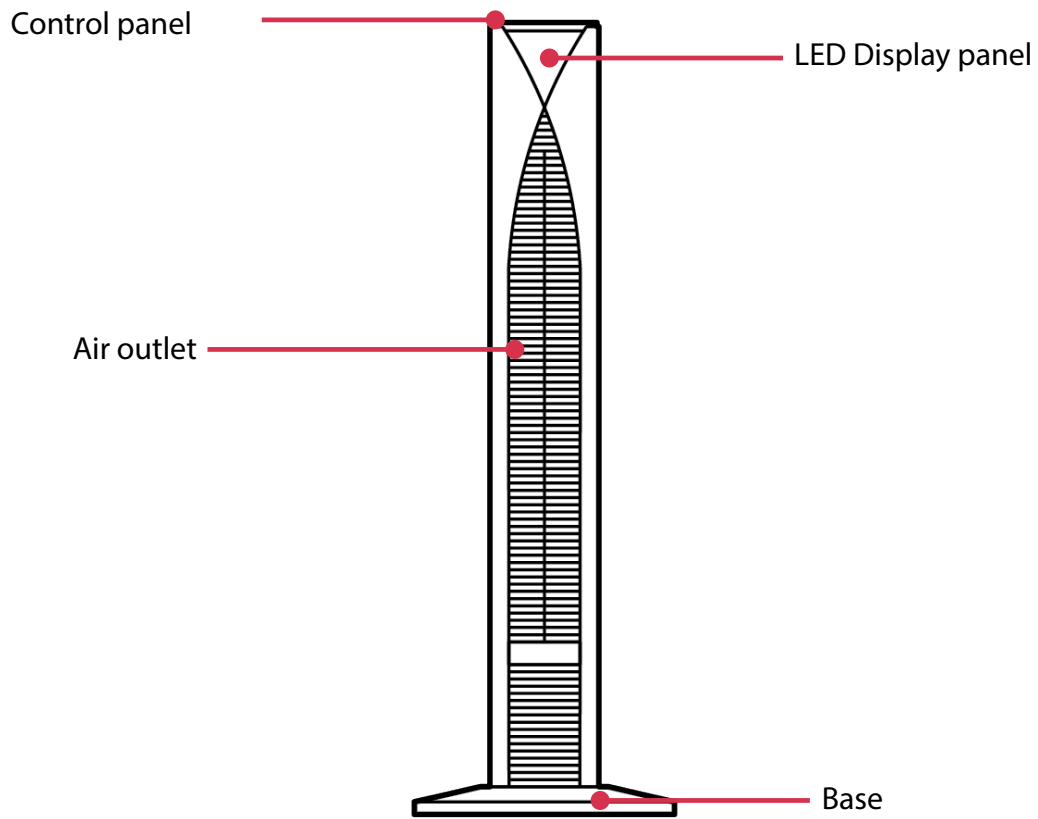

Remote

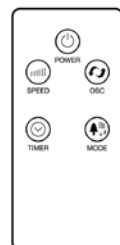

Assembly

The base of the tower fan comes in two parts, which fit around the oscillation base. Both parts fit easily together.

1. First attach the front half of the base, aligning the holes in the base with the screw hole in the oscillation base and lead the power cord up the base.
2. Connect the back half of the base to the front half and secure with the plastic screw nut (supplied) and twist it clockwise.
3. Plug into an appropriate power supply.

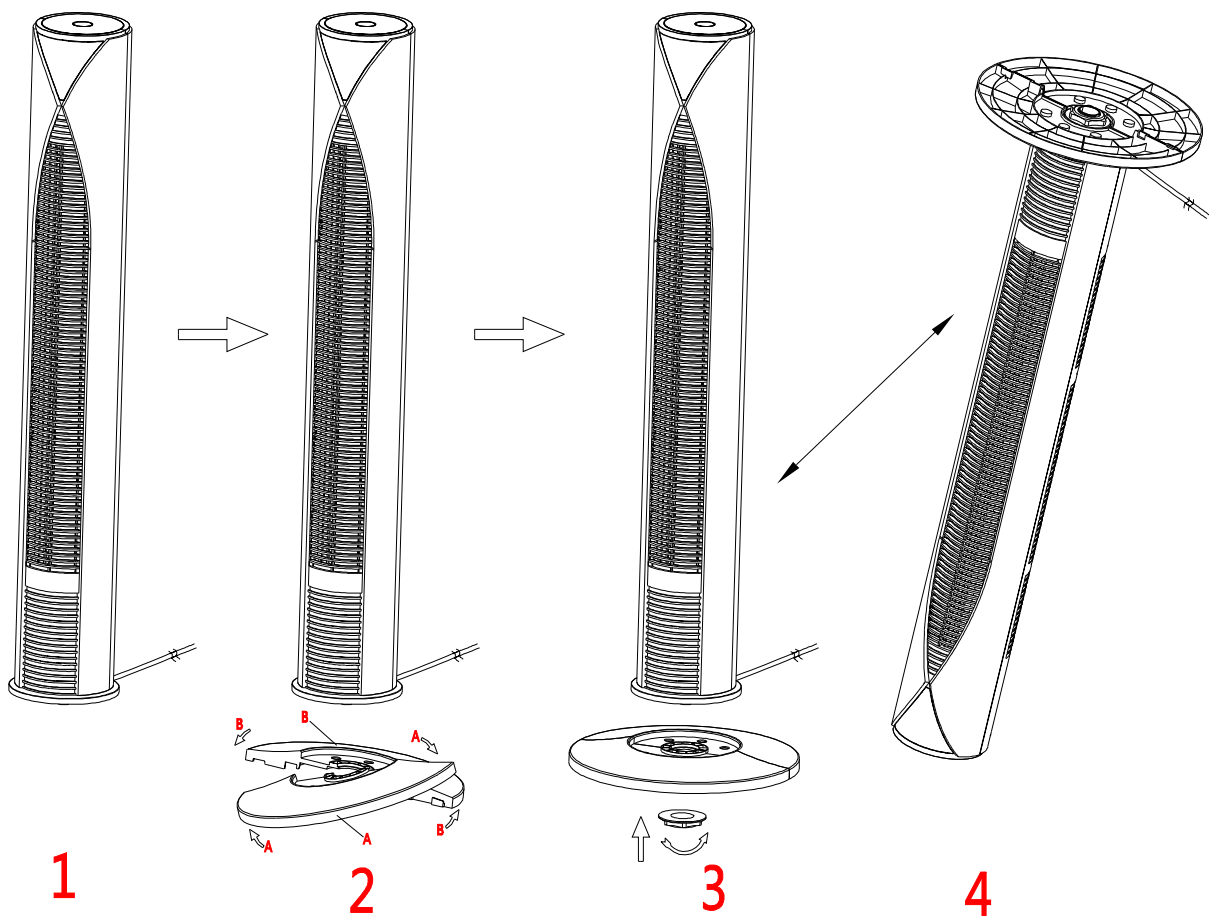

Operation

This tower fan can be operated by the control panel or remote control. Please refer to the below diagrams for descriptions.

Control Panel

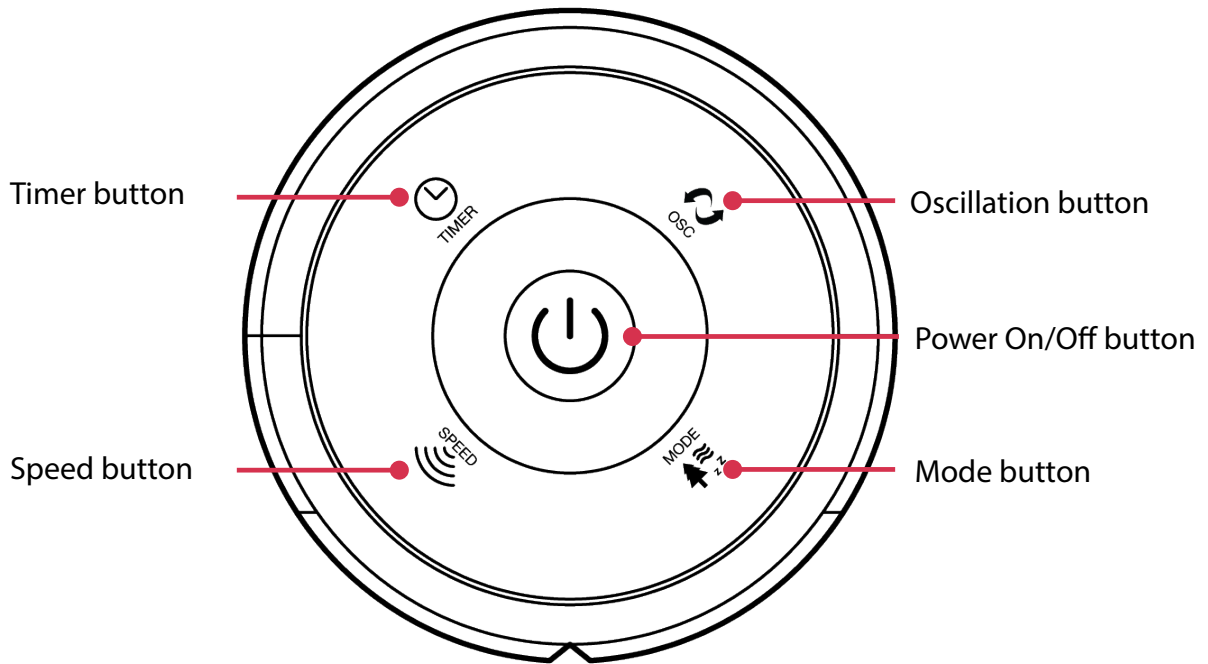

LED Display

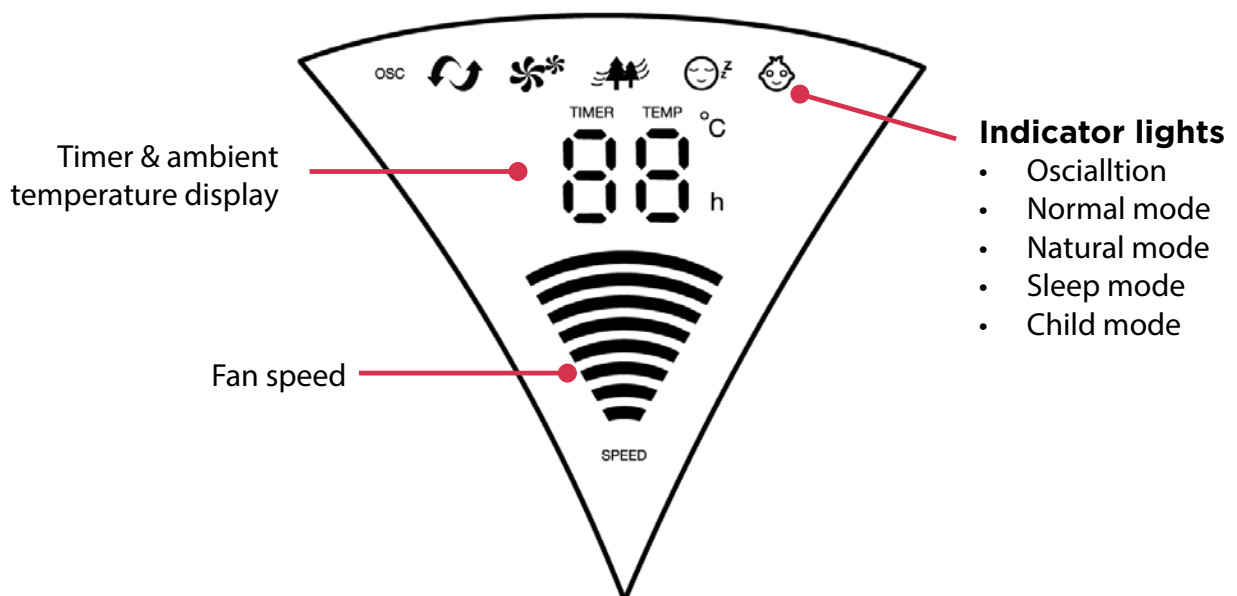

Operation

1. Place the fan on a flat stable surface. Plug into an electrical outlet and press the “Power On/Off” button to turn the unit “On”. The current room temperature will show on the LED display.
2. Adjust the fan speed by pressing the “Speed” button. There are three speeds - Low, Medium & High and each press will cycle through the speed settings. The speed setting will show on the LED display.
3. Press the “Mode” button to cycle through, Normal, Natural, Sleep & Child modes. The indicator light of the chosen mode will illuminate on the LED display.
4. This unit has a 12 hour timer that can be set in 1 hour increments. Press the “Timer” button until the desired time is shown on the LED display.
5. Press the “Oscillation” button to enable oscillation. Press again to disable.

Modes

Normal: When this mode is selected, the fan will operate as normal, in the settings selected.

Natural: This mode cycles through Low, Medium, High for 15 seconds each.

Sleep: The sleep mode varies depending on what speed the fan is working in at the time of selection. Refer to the below examples:

Low Speed - the fan will work at this speed without change until it is turned off (either manually or by the timer).

Medium speed - the fan will work at medium speed for 30 minutes, then switch to low speed until it is turned off.

High Speed - the fan will work at high speed for 30 minutes, then switch to medium speed for 30 minutes, and finally work in low speed before it is turned off.

Child: The timer sets at 3 hours and oscillation starts. The fan will work at high speed for 15 minutes, before changing to medium speed for 15 minutes, and then finishing in low speed until it automatically turns off. **NOTE:** The oscillation function can be turned off manually and it won't interrupt the Child mode settings.

Cleaning

Over time, dust can accumulate on the fan grille, which can affect the fans performance. It is recommended to clean the fan at least once a month.

1. Turn the unit OFF and disconnect the appliance from the power supply.
2. Remove any dust build up with a soft brush.
3. Wipe the surface of the unit with a soft damp cloth. Mild detergent can be used for any stubborn marks.

Do not use abrasive sponges, scouring pads, or a stiff brush to clean the unit.

IMPORTANT

The control panel and other parts must not come into contact with water or any other liquids.

Storage

If not using the unit for an extended period of time. After cleaning please:

- Turn the unit off, unplug and take care of the mains lead & plug.
- Cover the unit and store it upright in a location where it will not receive direct sunlight.
NB- Prolonged exposure to direct sunlight will discolour the enclosure.

Maintenance

If the unit fails to operate efficiently, is broken or other problems arise, unplug and do not operate. Ask for advice by calling your local after sales service agent or the Customer Care Centre on 1300 556 816 (AU) / 0800 666 2824 (NZ).

Warranty

Please refer to the warranty card in the box for warranty information. For any troubleshooting advice, please contact the relative Customer Care Centre below.

Glen Dimplex Australia Pty Ltd

8 Lakeview Drive,
Scoresby 3179, Victoria
Australia
Ph: 1300 556 816

Glen Dimplex New Zealand Ltd

38 Harris Road, East Tamaki,
Auckland 2013
New Zealand
Ph: 0800 666 2824

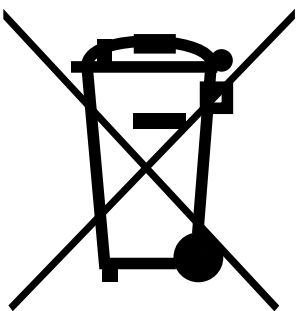

Recycling: Do not dispose of electrical appliances as unsorted municipal waste. Use separate collection facilities. Contact your local government for information regarding the collection systems available. If electrical appliances are disposed of in landfills or dumps, hazardous substances can leak into the ground water, polluting the food chain and damaging health and well-being.



Customer Care: 1300 556 816
customer.care@glendimplex.com.au
www.dimplex.com.au

Supplied by Glen Dimplex Australia
8 Lakeview Drive, Scoresby, Victoria, 3179

© Glen Dimplex Australia. All rights reserved. Material contained in this publication may not be reproduced in whole or in part, without prior permission in writing of Glen Dimplex Australia.

DCTFE97 REV2