

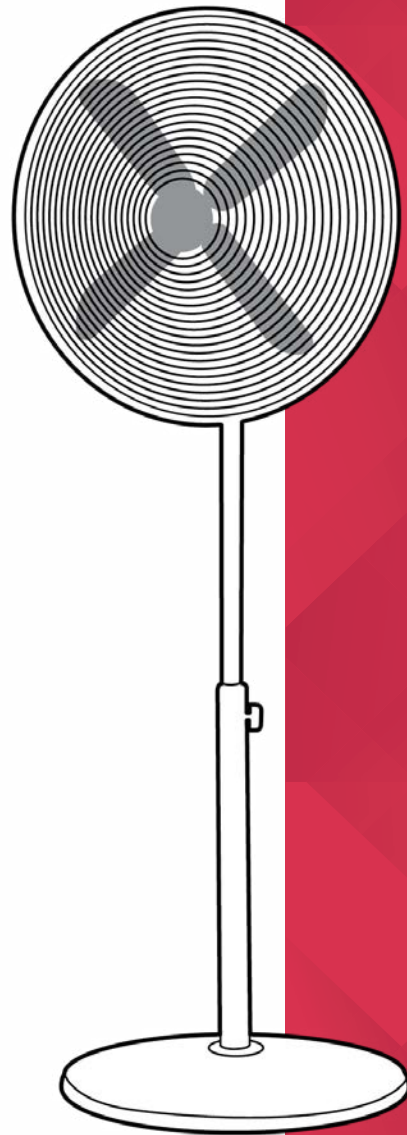

## INSTRUCTION MANUAL



### **40cm HV Pedestal Fan**

Model: DCPF40C & DCPF40MB

---

For domestic household use only.



## IMPORTANT

THESE INSTRUCTIONS SHOULD BE READ CAREFULLY AND RETAINED FOR FUTURE REFERENCE. **Note also the information presented on the appliance**

### **CAUTION: FAILURE TO FOLLOW THESE INSTRUCTIONS MAY CAUSE INJURY AND/OR DAMAGE AND MAY INVALIDATE YOUR WARRANTY**

Please read the operating instructions carefully before using your fan for the first time and keep them in a safe place.

**WARNING** – This appliance must not be used in a bathroom.

**WARNING** – Do not use this appliance in the immediate surroundings of a bath, a shower or a swimming pool.

- Never immerse the appliance in water or other liquids.
- Operate this unit only on a firm, flat surface.
- Do not place on soft, unstable or non-horizontal/angled surfaces.
- Never operate the appliance if a cable or connector has been damaged, after appliance malfunction or if the appliance was dropped or is otherwise damaged.
- If the mains lead is damaged it must only be replaced by the manufacturers service agent or a similarly qualified person in order to avoid a hazard.
- Please ask a professional service agent to repair the product. Improper repair may cause danger to users.
- Disconnect the appliance from mains power whenever it is not in use, before relocating it, and before cleaning.
- Operate the appliance only at the voltage specified on the rating label.
- Only connect the unit to a properly installed and easily accessible socket so that you can quickly disconnect the plug if necessary.
- Do not connect this product to the mains using an extension lead.
- This fan is only intended for **INDOOR RESIDENTIAL** applications. This fan should not be used for commercial or industrial or leisure applications or in small enclosed spaces.
- Never use the mains lead as a carrying strap or pulling lead.
- To avoid a fire or electrocution hazard, **NEVER** put the cord near heat registers, radiator, stoves or heaters.
- **DO NOT** cover cord with carpeting, throw rugs, runners, or similar coverings.
- **DO NOT** route cord under furniture or appliances. Take care to position the cord away from traffic areas and where it will not be a tripping hazard.
- **DO NOT** use the unit near windows or where water collects. Rain and water collection may lead to a risk of fire or electric shock.
- Only operate this appliance with a minimum of 50cm clearance all around i.e. away from walls, furniture and overhanging objects such as curtains or a shelf.
- This appliance is not intended for use by persons (including children) with reduced physical, sensory or mental capabilities, or lack of experience and knowledge, unless they have been given supervision or instruction concerning use of the appliance by a person responsible for their safety.

- Children should be supervised to ensure they do not play with the appliance.
- **WARNING:** To avoid danger of suffocation please remove all packaging materials particularly plastic and EPS and keep these away from vulnerable people, children and babies.
- **NEVER** drop or insert any object or fingers into any openings.
- Do not use the appliance in locations where paint, petrol or other flammable liquids are used or stored.
- If the supply cord is damaged, it must be replaced by the manufacturer, its service agent or similarly qualified persons in order to avoid a hazard.
- Do not use bug sprays or other flammable cleansers/vapour sprays on or around the unit.
- Always switch off the unit and take the plug out of the socket:
  - If you are not using the unit
  - Before you clean or carry out maintenance on the unit
  - If a fault occurs
  - In the event of an electrical storm.
- Avoid electromagnetic interference. Keep the unit at least 1 metre away from electrical appliances such as televisions & radios.

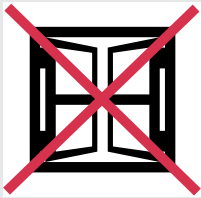

Exposed to the weather outdoors



Near water



If the power cable wires are frayed or cut



Where small children may be left unattended

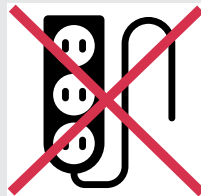

If an extension lead may become overloaded



Where the power cable may be damaged



On a slope or uneven surface



Where there is risk of fire or close to a naked flame



Where it may be damaged by chemicals



Where there is a risk of interference by foreign objects



This product is not made for DIY repair



If there is a risk of water falling on the unit

## Specification

<b>Model no.</b>	<b>DCPF40C</b>	<b>DCPF40MB</b>
Colour	Chrome	Matte Black
Power supply	220-240V~, 50Hz	
Rated power	60W	
Speed settings	3	
Modes	-	
Timer	-	
Air volume	141m <sup>3</sup> /min	
Adjustable height	Yes - Max height 1.25m	
Tilt adjustable head	Y	
Horizontal oscillation	Y	
Noise level	77dB(A)	
Weight (net)	5.6kg	
Dimensions (w x d x h)	450 x 410 x 1250mm	

- For greater precision, please always refer to the rating label placed on the product.

# Parts

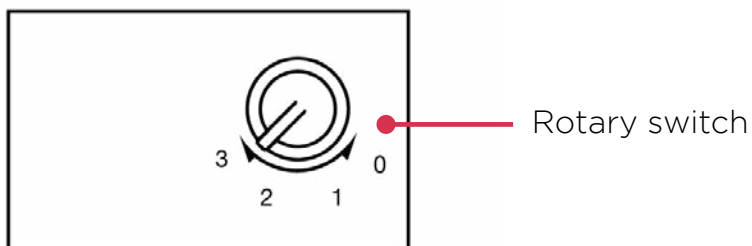
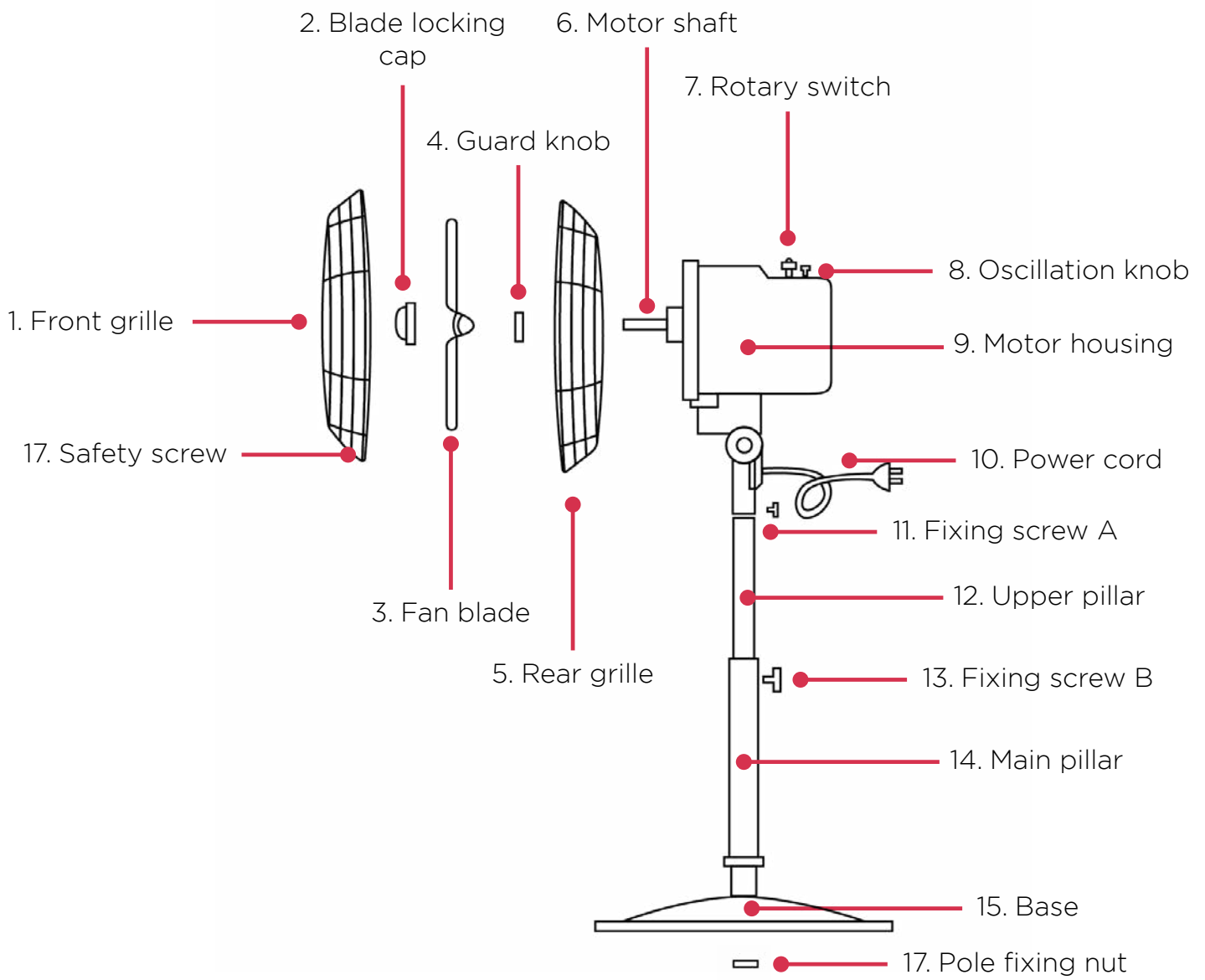

## Assembly

1. Remove the pole fixing nut (16) from the main pillar (14) and insert the main pillar (14) into the base (15) then tighten the fixing nut (16).
2. Release fixing screw B (13) and adjust height to a suitable length. Re-tighten the fixing screw B once ready.
3. Release the fixing screw A (11), connect the motor housing with the upper pillar (12), fasten it with the fixing screw A (11).
4. Remove the blade locking cap (2) and the guard knob (4) from the motor shaft (6), secure the rear guard (5) on the motor housing (9) to line up with the three fixing pins, fasten the guard with the guard knob (4).
5. Put the blade (3) on the motor shaft (6) and tighten with the blade locking cap (2).
6. Attach the front guard (1) to the rear guard (5), and close the guard fixing clips, finally fastening with the safety screw (17)

## Operation

1. Connect the plug to a power supply and switch on the power.
2. Switch the fan **ON** by rotating the speed control knob (7) at the rear in clockwise direction.
3. The switch is also used to adjust the fan **SPEED**.
4. The airflow direction can be adjusted upward/downward by lifting up or pressing down the motor housing.

**NOTE:** Only adjust the fan head when the unit is OFF. Be careful not to insert your fingers through the guard.

5. Push the oscillating knob (8) down to start **OSCILLATION**. Pull the oscillation knob up to stop **OSCILLATION**.
6. Turn speed control knob (7) to adjust the fan speed from LOW "1" - MEDIUM "2" - HIGH "3" in sequence. Turn the switch anti-clockwise to the "0" position to turn OFF.
7. Turn the switch anti-clockwise to the "0" position to turn the fan **OFF**. Speed

## Cleaning

Over time, dust can accumulate on the front & rear grille cover and fan blades, which can affect the fans performance. It is recommended to clean the fan at least once a month.

1. Turn the unit OFF and disconnect the appliance from the power supply.
2. Remove any dust build up with a soft brush.
3. Wipe the surface of the unit with a soft damp cloth. Mild detergent can be used for any stubborn marks.

**Do not** use abrasive sponges, scouring pads, or a stiff brush to clean the

### **IMPORTANT**

The control panel and other parts must not come into contact with water or any other liquids.

### **Storage**

If not using the unit for an extended period of time. After cleaning please:

- Turn the unit off, unplug and take care of the mains lead & plug.
- Cover the unit and store it upright in a location where it will not receive direct sunlight.  
NB- Prolonged exposure to direct sunlight will discolour the enclosure.



## Maintenance

If the unit fails to operate efficiently, is broken or other problems arise, unplug and do not operate. Ask for advice by calling your local after sales service agent or the Customer Care Centre on 1300 556 816 (AU) / 0800 666 2824 (NZ).

## Warranty

Please refer to the warranty card in the box for warranty information. For any troubleshooting advice, please contact the relative Customer Care Centre below.

### **Glen Dimplex Australia Pty Ltd**

1340 Ferntree Gully Road,  
Scoresby 3179, Victoria  
Australia  
Ph: 1300 556 816

### **Glen Dimplex New Zealand Ltd**

38 Harris Road, East Tamaki,  
Auckland 2013  
New Zealand  
Ph: 0800 666 2824

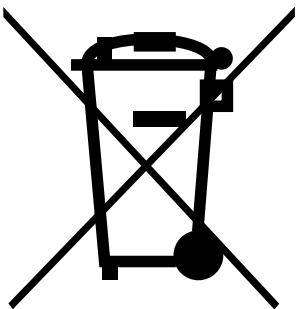

*Recycling: Do not dispose of electrical appliances as unsorted municipal waste. Use separate collection facilities. Contact your local government for information regarding the collection systems available. If electrical appliances are disposed of in landfills or dumps, hazardous substances can leak into the ground water, polluting the food chain and damaging health and well-being.*



**Customer Care:** 1300 556 816  
customer.care@glendimplex.com.au  
www.dimplex.com.au

Supplied by Glen Dimplex Australia  
1340 Ferntree Gully Road, Scoresby, Victoria, 3179

---

© Glen Dimplex Australia. All rights reserved. Material contained in this publication may not be reproduced in whole or in part, without prior permission in writing of Glen Dimplex Australia.