

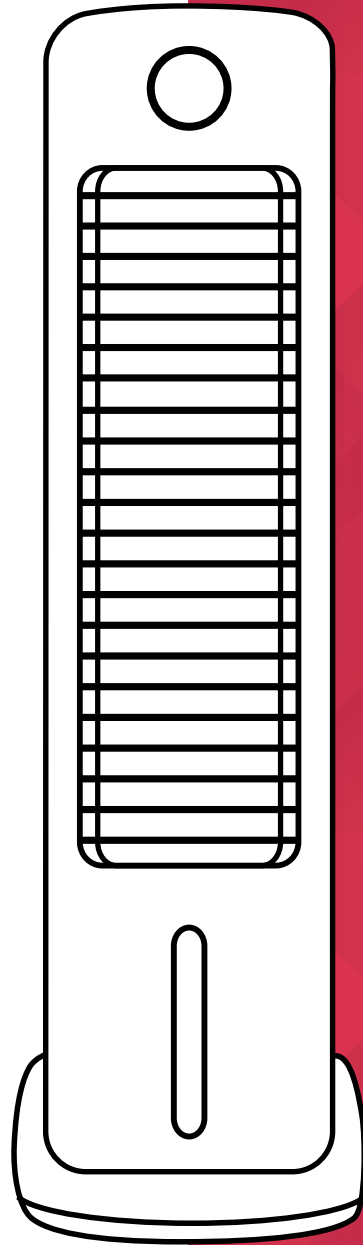

INSTRUCTION MANUAL



8L Evaporative Cooler

Model: DCEVP8BW

For domestic household use only.



IMPORTANT

THESE INSTRUCTIONS SHOULD BE READ CAREFULLY AND RETAINED FOR FUTURE REFERENCE. **Note also the information presented on the appliance**

CAUTION: FAILURE TO FOLLOW THESE INSTRUCTIONS MAY CAUSE INJURY AND/OR DAMAGE AND MAY INVALIDATE YOUR WARRANTY

Please read the operating instructions carefully before using your evaporative cooler for the first time and keep them in a safe place.

WARNING - This appliance must not be used in a bathroom.

WARNING - Do not use this appliance in the immediate surroundings of a bath, a shower or a swimming pool.

- Never immerse the appliance in water or other liquids.
- Unplug the appliance during filling and cleaning.
- Operate this unit only on a firm, flat surface to avoid the risk of water leakage. Ensure that the unit is kept upright at all times.
- Do not place on soft, unstable or non-horizontal/angled surfaces.
- Never operate the appliance if a cable or connector has been damaged, after appliance malfunction or if the appliance was dropped or is otherwise damaged.
- If the mains lead is damaged it must only be replaced by the manufacturers service agent or a similarly qualified person in order to avoid a hazard.
- Please ask a professional service agent to repair the product. Improper repair may cause danger to users.
- Disconnect the appliance from mains power whenever it is not in use, before relocating it, filling it and before cleaning.
- Operate the appliance only at the voltage specified on the rating label.
- Only connect the unit to a properly installed and easily accessible socket so that you can quickly disconnect the plug if necessary.
- Do not connect this product to the mains using an extension lead.
- This evaporative cooler is only intended for **INDOOR RESIDENTIAL** applications. This evaporative cooler should not be used for commercial or industrial or leisure applications or in small enclosed spaces.
- Never use the mains lead as a carrying strap or pulling lead.
- To avoid a fire or electrocution hazard, **NEVER** put the cord near heat registers, radiator, stoves or heaters.
- **DO NOT** touch the power cord with wet hands to avoid the risk of electric shock.
- **DO NOT** cover cord with carpeting, throw rugs, runners, or similar coverings.
- **DO NOT** route cord under furniture or appliances. Take care to position the cord away from traffic areas and where it will not be a tripping hazard.
- **DO NOT** use the unit near windows or where water collects. Rain and water collection may lead to a risk of fire or electric shock.
- Only operate this appliance with a minimum of 50cm clearance all around i.e. away from walls, furniture and overhanging objects such as curtains or a shelf.

- This appliance is not intended for use by persons (including children) with reduced physical, sensory or mental capabilities, or lack of experience and knowledge, unless they have been given supervision or instruction concerning use of the appliance by a person responsible for their safety.
- Children should be supervised to ensure they do not play with the appliance.
- To prevent spillage, empty the water tank before lifting or relocating the appliance.
- **WARNING:** To avoid danger of suffocation please remove all packaging materials particularly plastic and EPS and keep these away from vulnerable people, children and babies.
- **NEVER** drop or insert any object or fingers into any openings.
- Do not use the appliance in locations where paint, petrol or other flammable liquids are used or stored.
- Do not use bug sprays or other flammable cleansers/vapour sprays on or around the unit.
- Always switch off the unit and take the plug out of the socket:
 - If you are not using the unit
 - Before you clean or carry out maintenance on the unit
 - If a fault occurs
 - During filling
 - In the event of an electrical storm
- Avoid electromagnetic interference. Keep the unit at least 1 metre away from electrical appliances such as televisions & radios.
- Never insert objects or fingers into the air inlet and outlet, it may lead to current leakage, short circuit and product damage.

WARNING - KEEP BATTERIES OUT OF REACH OF CHILDREN

- Swallowing may lead to serious injury in as little as 2 hours or death, due to chemical burns and potential perforation of the oesophagus.
- If you suspect your child has swallowed or inserted a button battery immediately call the 24-hour Poisons Information Centre on 13 11 26 (in Australia) or 0800 764 766 (in New Zealand) for fast, expert advice.
- Examine devices and make sure the battery compartment is correctly secured, e.g. that the screw or other mechanical fastener is tightened. Do not use if the compartment is not secure.
- Dispose of used button batteries immediately and safely. Flat batteries can still be dangerous.





Exposed to the weather outdoors



Near water



If the power cable wires are frayed or cut



Where small children may be left unattended

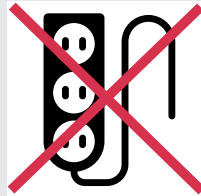

If an extension lead may become overloaded



Where the power cable may be damaged



On a slope or uneven surface



Where there is risk of fire or close to a naked flame



Where it may be damaged by chemicals



Where there is a risk of interference by foreign objects



This product is not made for DIY repair



If there is a risk of water falling on the unit

Specification

Model no.	DCEVP8BW
Colour	Black/White
Power supply	220-240V-50Hz
Rated power	80W
Speed settings	3
Modes	3 (natural, normal & sleep)
Turbo air speed	7m/s
Water tank capacity	8L
Remote control	Y
Timer	0-9 hours
Swing function	Y
Controls	Button with LED display
Max. room size	20m ²
Water consumption	1L/h (high speed)
Weight (net)	7kg
Dimensions (w x d x h)	270 x 325 x 1062mm

- For greater precision, please always refer to the rating label placed on the product.

Parts

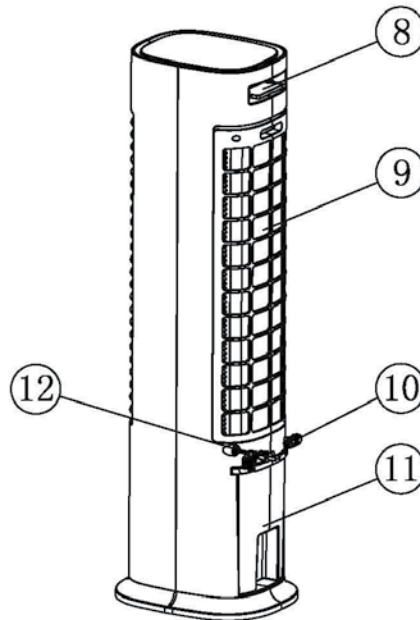
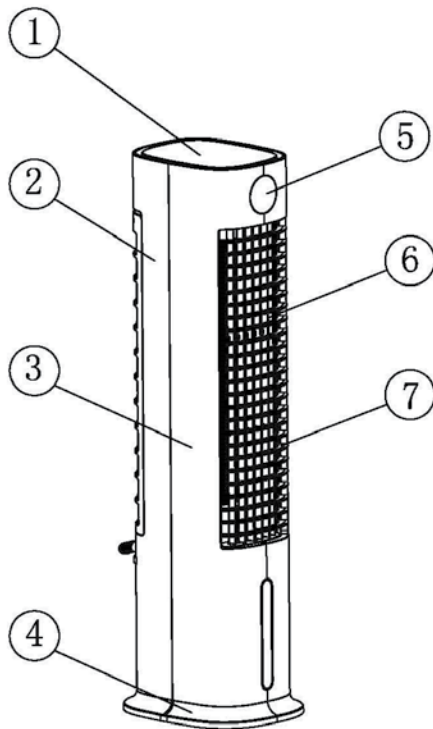

- (1) Top panel
- (2) Rear panel
- (3) Front panel
- (4) Base
- (5) Display
- (6) Vertical blade
- (7) Horizontal blade

- (8) Remote control storage
- (9) Rear screen
- (10) Cord winding frame
- (11) Water tank
- (12) Power cord

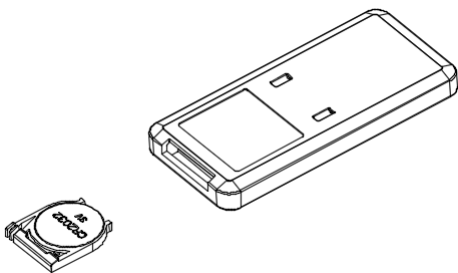

Remote



Ice pack x 2

Display & Control Panels

Control Panel

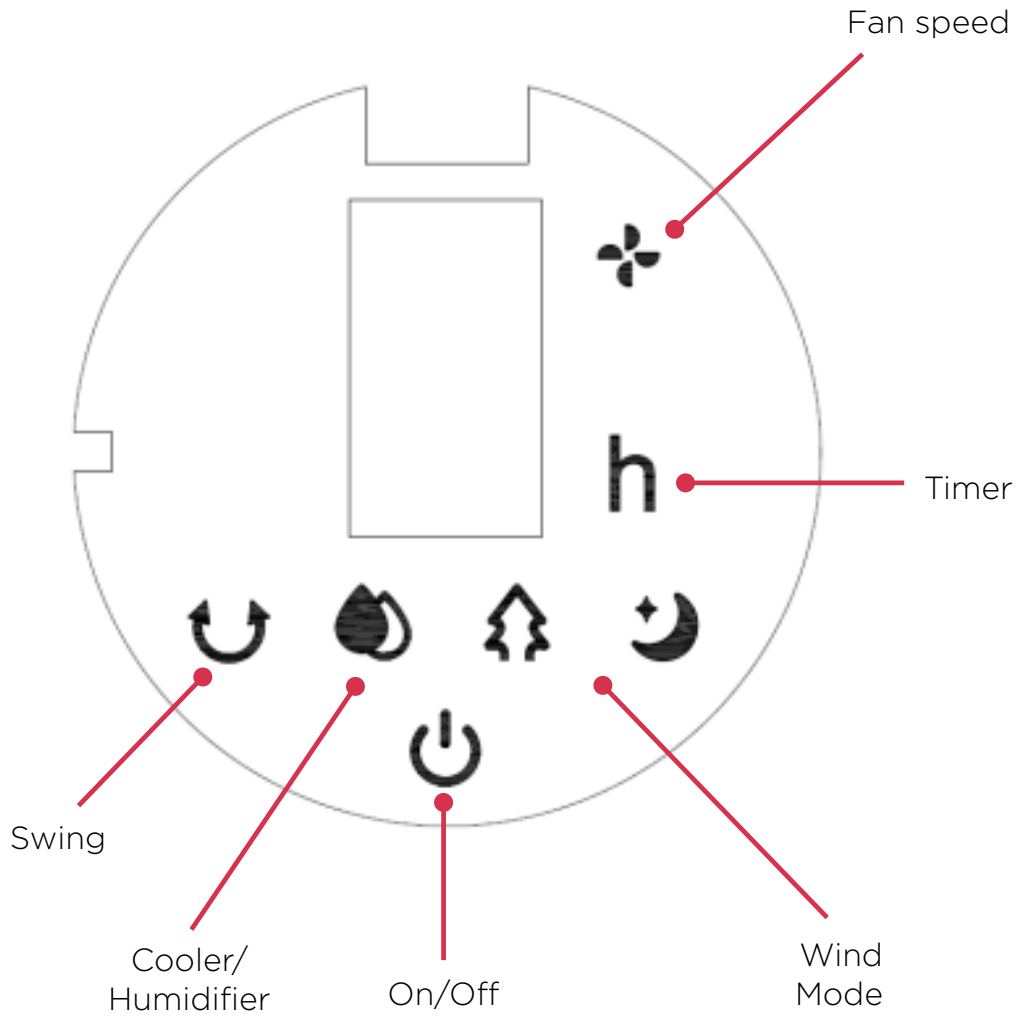

Display Panel

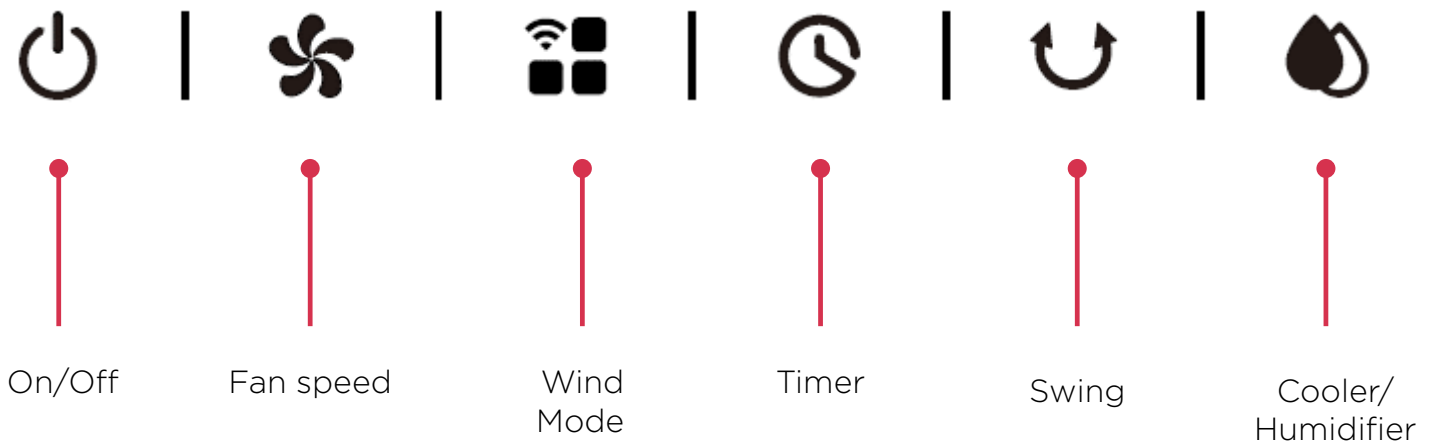

Remote Control

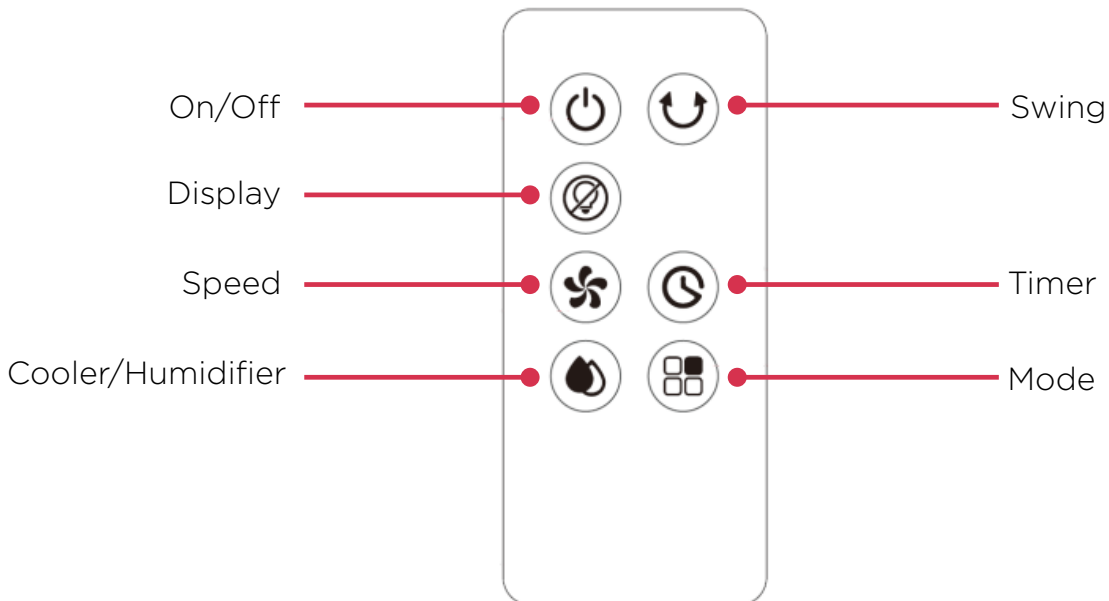

Functions

Note: The buzzer beeps twice when the power supply is first turned on. The unit is in 'standby' until the On/Off button is pressed. The horizontal louvres need to be opened manually by hand.

ON/OFF

Press the **ON/OFF** button to turn the unit **ON**. The default settings when first turned on are low fan speed, normal wind mode, and no timer. When turning the unit back on after powering it off, the state upon turning it off will be memorised, excluding the timer setting. If the sleep wind mode was on before turning off, the mode will not be memorized after turning it on again, but the normal wind mode will start. To turn the unit **OFF** press this button again. It may take a few seconds to power off completely.

SWING

Press this button to turn on the **SWING** function, the vertical louvres will move left to right as the synchronous motor switches on/off the vertical fan blades.

SPEED

The fan **SPEED** can be selected in the following sequence: low (1) > medium (2) > high (3) > low (1)... The selected fan speed LED indicator light will illuminate accordingly.

TIMER

The **TIMER** can be set in 1 hour increments up to the maximum timer of 9 hours. The set time will be indicated on the display panel and the time indicator turns on and the display panel flashes to display the set time, indicating that it is in the timer setting state. At this moment, you can press the timer button to set the time, and press any key (except the switch key) or wait 5 seconds to exit the setting. After setting the timer, the display panel alternately displays the set timer and current wind speed at 10 second intervals, and the wind speed indicator and time indicator display correspondingly. When the internal timing program reaches the set time, the machine will shut down and stay in standby state.

MODE

The default mode after turning “On” is normal. Press this button to select modes in this sequence: normal > natural > sleep. The **MODE** indicator light will illuminate accordingly. There is no indicator for the normal wind mode.

Normal: The fan runs at a fixed speed for the wind speed selected, without any change.

Natural: The fan motor runs irregularly according to the preset program, and can be set to low, medium and high natural wind in conjunction with the wind speed key. Natural wind is to imitate the effect of natural wind, making the air volume softer and more comfortable.

Sleep: In natural sleep mode, the wind speed changes with a 30-minute cycle change, but does not indicate with the change of natural wind. The fan motor performs timing downshifting operation mode according to the wind speed set by the user and preset rule of the program. This mode prevents physical discomfort due to excessive wind when people fall asleep.

High: 30 minutes high speed natural wind > 30 minutes medium level normal wind > 30 minutes low level normal wind (until turned off).

Medium: 30 minutes medium level normal wind > low level normal wind (until turned off).

Low: Low level normal wind (until turned off)..

COOLER / HUMIDIFIER

Press this button once to turn on the **COOLER / HUMIDIFIER** function, the pump will start and the **COOLER / HUMIDIFIER** LED will illuminate. Press this button again to turn off the cooling function, and to use as a fan only.

Other Functions

Environmental protection function:

In the power on state, if there is no operation of any key (including the remote control) for 1 minute all LEDs will dim to 33% of their original brightness. Press the key again to restore the brightness and perform the corresponding operation.

Water level protection function:

When the cooling function is first turned on, the water pump works for 50 seconds. If low water is detected, the pump will stop working and a buzzer alarm beeps 10 times.

Uninterrupted power memory function:

When the power is restored after a power outage, the fan will start in the state before shutting down when it is turned on again. The unit will restore to the previous settings. **Note:** the previous function will be restored (except if in sleep mode). The timer is not memorised either.

Operation & Set Up

1. Remove the unit from its packaging
2. To begin using the **COOLER/HUMIDIFIER** function, rotate the Cord winding frame clips 90° and remove the water tank located at the back of the unit and fill to the **MAX** fill line. Replace the water tank and secure the clips.
3. For extra cooling power, place an ice pack (supplied) into the water tank.
4. Open the horizontal louvres.
5. Plug into a power supply and press the **ON/OFF** button to start the appliance.
6. The unit will operate initially on a continual basis. If a set period of operation is required, please follow the **TIMER** instructions on page 9.
7. Select the desired fan **SPEED** by pressing the **SPEED** button. Refer to page 8 for different settings.
8. Select the operation **MODE** as required, by pressing the **MODE** button. Refer to page 9 for different settings.
9. Press the **SWING** function as required.
10. To switch the unit off at any time, press the **ON/OFF** button.

Precautions

- Do not overfill the water tank (check the MAX fill line).
- Only fill the water tank half full, when using the ice packs.
- Use only cold, clean filtered water.
- The unit is equipped with a number of safety devices, including a water level protection, uninterrupted power memory function & auto power off function.
- Do not allow the same water to sit in the machine for a prolonged period.
- It is recommended that any water left in the machine for 3 days or more be removed and replaced with clean water.
- The control panel must not come in contact with water or any other liquids.

Using the Remote Control

1. Unscrew and open the battery cover of the remote control, and insert a 3V CR2032 battery.
2. Please point to the receiver when using the remote control.
3. If the battery voltage is low, please open the battery cover and replace with a new battery (CR2032). Then replace the battery cover.

Your unit is designed to remove dirt and other atmospheric impurities by drawing air through the wet curtain. **DO NOT** block the air filter, as this will impair the efficiency of the unit.

Wet Curtain

- In a smoky or dusty environment, this wet curtain will become grey in colour after one to two months.
- Disconnect the unit from the main supply. Gently soak the wet curtain in mild, soapy water for a few minutes, dry and replace. Be sure to re-fit the rear screen securely. No special tools are required for this.

Water Tank

The water tank should be cleaned regularly, especially in hard water areas. If not cleaned, deposits may build up affecting the efficiency of the unit. Cleaning the tank with mild soapy water once every month is recommended. To do this, follow the steps below:

1. Disconnect the appliance from the main supply.
2. Completely remove the water tank from the unit by rotating the Cord winding frame clips 90° and removing the water tank by putting your hand into the water tank, rotate the fixing buckle 90°, and then push the water pump box assembly down to take it out, and finally take out the water tank. Remove any deposits or dirt from the tank with a mild, soapy detergent and cloth. **Note:** for hard water areas use a citric acid solution to descale & clean the tank. Mix 1 part citric acid to 20 parts water.
3. Flush the tank with clean water.
4. Replace the tank and make sure to secure it back in place by reversing the steps in point 2.

Outside Cabinet

1. Turn the unit OFF and disconnect the appliance from the power supply.
2. Remove any dust build up with a soft brush.
3. Wipe the surface of the unit with a soft damp cloth. Mild detergent can be used for any stubborn marks.

Do not use abrasive sponges, scouring pads, or a stiff brush to clean the

IMPORTANT

The control panel and other parts must not come into contact with water or any other liquids.

Storage

If not using the unit for an extended period of time. After cleaning please:

- Turn the unit off, unplug and take care of the mains lead & plug.
- Cover the unit and store it upright in a location where it will not receive direct sunlight. NB- Prolonged exposure to direct sunlight will discolour the enclosure.

Maintenance

If the unit fails to operate efficiently, is broken or other problems arise, unplug and do not operate. Ask for advice by calling your local after sales service agent or the Customer Care Centre on 1300 556 816 (AU) / 0800 666 2824 (NZ).

Warranty

Please refer to the warranty card in the box for warranty information. For any troubleshooting advice, please contact the relative Customer Care Centre below.

Glen Dimplex Australia Pty Ltd

8 Lakeview Drive,
Scoresby 3179, Victoria
Australia
Ph: 1300 556 816

Glen Dimplex New Zealand Ltd

38 Harris Road, East Tamaki,
Auckland 2013
New Zealand
Ph: 0800 666 2824

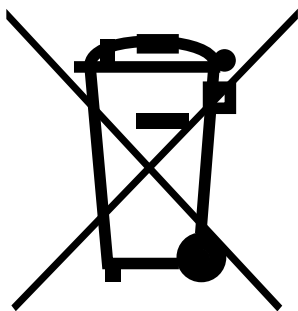

Recycling: Do not dispose of electrical appliances as unsorted municipal waste. Use separate collection facilities. Contact your local government for information regarding the collection systems available. If electrical appliances are disposed of in landfills or dumps, hazardous substances can leak into the ground water, polluting the food chain and damaging health and well-being.



Customer Care: 1300 556 816
customer.care@glendimplex.com.au
www.dimplex.com.au

Supplied by Glen Dimplex Australia
8 Lakeview Drive, Scoresby, Victoria, 3179

© Glen Dimplex Australia. All rights reserved. Material contained in this publication may not be reproduced in whole or in part, without prior permission in writing of Glen Dimplex Australia.

DCEVP8BW REV2