

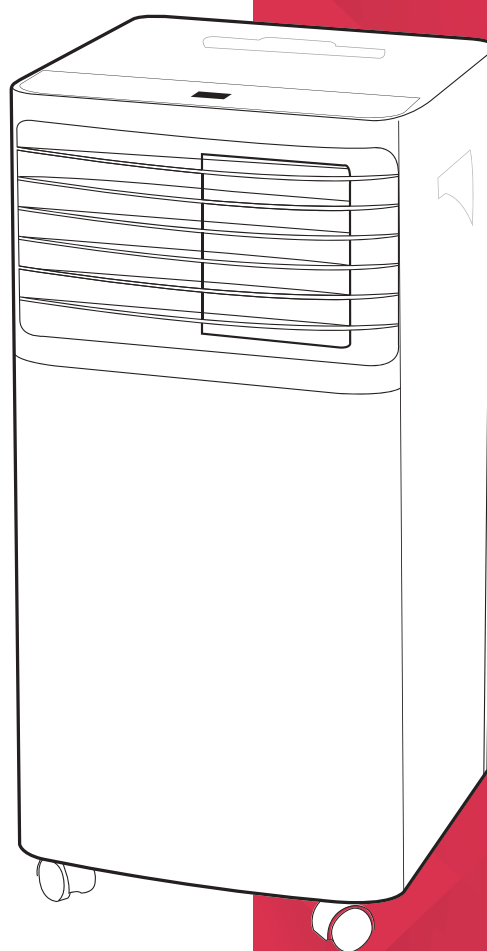

# INSTRUCTION MANUAL



## **Portable Air Conditioner**

Model: DCPAC07C

---

For domestic household use only.



## IMPORTANT

THESE INSTRUCTIONS SHOULD BE READ CAREFULLY AND RETAINED FOR FUTURE REFERENCE.

**Note also the information presented on the appliance**

### **CAUTION: FAILURE TO FOLLOW THESE INSTRUCTIONS MAY CAUSE INJURY AND/OR DAMAGE AND MAY INVALIDATE YOUR WARRANTY**

Please read the operating instructions carefully before using your Portable Air Conditioner for the first time and keep them in a safe place.

**WARNING** – This appliance must not be used in a bathroom.

**WARNING** – Do not use this appliance in the immediate surroundings of a bath, a shower or a swimming pool.

- If the mains lead is damaged it must only be replaced by the manufacturers service agent or a similarly qualified person in order to avoid a hazard.
- This appliance is not intended for use by persons (including children) with reduced physical, sensory or mental capabilities, or lack of experience and knowledge, unless they have been given supervision or instruction concerning use of the appliance by a person responsible for their safety.
- Children should be supervised to ensure they do not play with the appliance.
- Prior to cleaning or other maintenance, the appliance must be disconnected from the supply mains.
- Never immerse the appliance in water or other liquids.
- Operate this unit only on a firm, flat surface to avoid the risk of water leakage. Ensure that the unit is kept upright at all times.
- Do not place on soft, unstable or non-horizontal/angled surfaces.
- Never operate the appliance if a cable or connector has been damaged, after appliance malfunction or if the appliance was dropped or is otherwise damaged.
- Please ask a professional service agent to repair the product. Improper repair may cause danger to users.
- Disconnect the appliance from mains power whenever it is not in use, before relocating it, and before cleaning.
- Operate the appliance only at the voltage specified on the rating label.
- Only connect the unit to a properly installed and easily accessible socket so that you can quickly disconnect the plug if necessary.
- Do not connect this product to the mains using an extension lead.
- This product is only intended for **INDOOR RESIDENTIAL** applications. This product should not be used for commercial or industrial or leisure applications or in small enclosed spaces.
- Never use the mains lead as a carrying strap or pulling lead.
- To avoid a fire or electrocution hazard, **NEVER** put the cord near heat registers, radiator, stoves or heaters.
- **DO NOT** cover cord with carpeting, throw rugs, runners, or similar coverings.
- **DO NOT** route cord under furniture or appliances. Take care to position the cord away from traffic areas and where it will not be a tripping hazard.
- **DO NOT** use the unit near windows or where water collects. Rain and water collection

may lead to a risk of fire or electric shock.

- Only operate this appliance with a minimum of 50cm clearance all around i.e. away from walls, furniture and overhanging objects such as curtains or a shelf.
- **WARNING:** To avoid danger of suffocation please remove all packaging materials particularly plastic and EPS and keep these away from vulnerable people, children and babies.
- **NEVER** drop or insert any object or fingers into any openings.
- Do not cover or obstruct the air inlet and outlets.
- Do not use the appliance in locations where paint, petrol or other flammable liquids are used or stored.
- Do not use bug sprays or other flammable cleansers/vapour sprays on or around the unit.
- Always switch off the unit and take the plug out of the socket:
  - If you are not using the unit
  - Before you clean or carry out maintenance on the unit
  - If a fault occurs
  - In the event of an electrical storm.
- Avoid electromagnetic interference. Keep the unit at least 1 metre away from electrical appliances such as televisions & radios.
- The air conditioner must always be stored and transported upright. In case of doubt we suggest you wait for at least 24 hours before operation. (Please keep unit upright at all times)
- This portable air conditioner is fitted with a compressor delay protection circuit. This protects the unit from possible damage due to rapid starting and stopping of its compressor. The compressor will begin operating 3 minutes after the unit has been switched **ON** or if the mode is changed from dehumidify to cooling.
- It is hazardous for anyone other than an Authorised Service Person to service this appliance. In Queensland - the authorised Service Person **MUST** hold a Gas Work Authorisation for hydrocarbon refrigerants to carry out servicing or repairs where the gas system is being opened or charged.
- This appliance shall be installed in accordance with national wiring regulations.



**WARNING: For using R290 refrigerant. This symbol shows that this appliance uses a flammable refrigerant. If the refrigerant is leaked and exposed to an external ignition source, there is a risk of fire.**

**CAUTION: RISK OF FIRE/FLAMMABLE MATERIALS. THE APPLIANCE MUST BE INSTALLED, USED & STORED IN AN AREA THAT IS GREATER THAN 13m<sup>2</sup>.**



NB: These symbols on your device mean:

- This appliance is filled with Propane gas R290. Follow strictly the manufacturer's instruction concerning use and repairs!
- Before using this appliance, you must carefully read the entire instruction manual.
- Do not install, operate or store the device in a room with a floor area smaller than 13m<sup>2</sup>.
- Repairs must be performed based on the recommendations from the manufacturing company.
- Note also the information presented on the appliance.
- Do not use means to accelerate the defrosting process or to clean, other than those recommended by the manufacturer.
- The appliance shall NOT be stored in a room with continuously operating ignition sources (for example: open flames, an operating gas appliance or an operating electric heater).
- Do not pierce or burn.
- Be aware that the refrigerants may not contain an odour.
- The appliance should be installed, operated and stored in a room with a floor area according to the amount of refrigerant to be charged. For specific information on the type of gas and the amount, please refer to the relevant label on the unit itself. When there are differences between the label and the manual on the Min. room area description, the description on label shall prevail.
- Compliance with national gas regulations shall be observed.
- Keep ventilation openings clear of obstruction.
- The appliance shall be stored so as to prevent mechanical damage from occurring.
- A warning that the appliance shall be stored in a well-ventilated area where the room size corresponds to the room area as specified for operation.
- Any person who is involved with working on or breaking into a refrigerant circuit should hold a current valid certificate from an industry-accredited assessment authority, which authorises their competence to handle refrigerants safely in accordance with an industry recognised assessment specification.
- Servicing shall only be performed as recommended by the equipment manufacturer. Maintenance and repair requiring the assistance of other skilled personnel shall be carried out under the supervision of the person competent in the use of flammable refrigerants.

1. Transport of equipment containing flammable refrigerants - see transport regulations
2. Marking of equipment using signs - see local regulations
3. Disposal of equipment using flammable refrigerants - see national regulations.
4. Storage of equipment/appliances - The storage of equipment should be in accordance with the manufacturer's instructions.
5. Storage of packed (unsold) equipment - storage package protection should be constructed such that mechanical damage to the equipment inside the package will not cause a leak of the refrigerant charge. The maximum number of pieces of equipment permitted to be stored together will be determined by local regulations.
6. Information on servicing
  - **Checks to the area**

Prior to beginning work on systems containing flammable refrigerants, safety checks are necessary to ensure that the risk of ignition is minimised. For repair to the refrigerating system, the following precautions shall be complied with prior to conducting work on the system.
  - **Work procedure**

Work shall be undertaken under a controlled procedure so as to minimise the risk of a flammable gas or vapour being present while the work is being performed.
  - **General work area**

All maintenance staff and others working in the local area shall be instructed on the nature of work being carried out. Work in confined spaces shall be avoided. The area around the workspace shall be sectioned off. Ensure that the conditions within the area have been made safe by control of flammable material.
  - **Checking for presence of refrigerant**

The area shall be checked with an appropriate refrigerant detector prior to and during work, to ensure the technician is aware of potentially flammable atmospheres. Ensure that the leak detection equipment being used is suitable for use with flammable refrigerants, i.e. non-sparking, adequately sealed or intrinsically safe.
  - **Presence of fire extinguisher**

If any hot work is to be conducted on the refrigeration equipment or any associated parts, appropriate fire extinguishing equipment shall be available to hand. Have a dry powder or CO<sub>2</sub> fire extinguisher adjacent to the charging area.
  - **No ignition sources**

No person carrying out work in relation to a refrigeration system which involves exposing any pipe work that contains or has contained flammable refrigerant shall use any sources of ignition in such a manner that it may lead to the risk of fire or explosion. All possible ignition sources, including cigarette smoking, should be kept sufficiently far away from the site of installation, repairing, removing and disposal, during which flammable refrigerant can possibly be released to the surrounding space. Prior to work taking place, the area around the equipment is to be surveyed to make sure that there are no flammable hazards or ignition risks. No Smoking signs shall be displayed.
  - **Ventilated area**

Ensure that the area is in the open or that it is adequately ventilated before breaking into the system or conducting any hot work. A degree of ventilation shall continue during the period that the work is carried out. The ventilation should safely disperse any released refrigerant and preferably expel it externally into the atmosphere.

- **Checks to the refrigeration equipment**

Where electrical components are being changed, they shall be fit for the purpose and to the correct specification. At all times the manufacturer's maintenance and service guidelines shall be followed. If in doubt consult the manufacturer's technical department for assistance. The following checks shall be applied to installations using flammable refrigerants:

The charge size is in accordance with the room size within which the refrigerant containing parts are installed;

The ventilation machinery and outlets are operating adequately and are not obstructed;

If an indirect refrigerating circuit is being used, the secondary circuit shall be checked for the presence of refrigerant; Marking to the equipment continues to be visible and legible. Markings and signs that are illegible shall be corrected; Refrigeration pipe or components are installed in a position where they are unlikely to be exposed

to any substance which may corrode refrigerant containing components, unless the components are constructed of materials which are inherently resistant to being corroded or are suitably protected against being so corroded.

- **Checks to electrical devices**

Repair and maintenance to electrical components shall include initial safety checks and component inspection procedures. If a fault exists that could compromise safety, then no electrical supply shall be connected to the circuit until it is satisfactorily dealt with. If the fault cannot be corrected immediately but it is necessary to continue operation, an adequate temporary solution shall be used. This shall be reported to the owner of the equipment so all parties are advised.

Initial safety checks shall include:

That capacitors are discharged: this shall be done in a safe manner to avoid possibility of sparking; That there no live electrical components and wiring are exposed while charging, recovering or purging the system; That there is continuity of earth bonding.

- **Repairs to sealed components**

- During repairs to sealed components, all electrical supplies shall be disconnected from the equipment being worked upon prior to any removal of sealed covers, etc. If it is absolutely necessary to have an electrical supply to equipment during servicing, then a permanently operating form of leak detection shall be located at the most critical point to warn of a potentially hazardous situation.
- Particular attention shall be paid to the following to ensure that by working on electrical components, the casing is not altered in such a way that the level of protection is affected. This shall include damage to cables, excessive number of connections, terminals not made to original specification, damage to seals, incorrect fitting of glands, etc. Ensure that apparatus is mounted securely. Ensure that seals or sealing materials have not degraded such that they no longer serve the purpose of preventing the ingress of flammable atmospheres. Replacement parts shall be in accordance with the manufacturer's specifications.

**NOTE:** The use of silicon sealant may inhibit the effectiveness of some types of leak detection equipment. Intrinsically safe components do not have to be isolated prior to working on them.

- **Repair to intrinsically safe components**

Do not apply any permanent inductive or capacitance loads to the circuit without ensuring that this will not exceed the permissible voltage and current permitted for the equipment in use. Intrinsically safe components are the only types that can be worked on while live in the presence of a flammable atmosphere. The test apparatus shall be at the correct rating. Replace components only with parts specified by the manufacturer. Other parts may result in the ignition of refrigerant in the atmosphere from a leak.

- **Cabling**

Check that cabling will not be subject to wear, corrosion, excessive pressure, vibration, sharp edges or any other adverse environmental effects. The check shall also take into account the effects of aging or continual vibration from sources such as compressors or fans.

- **Detection of flammable refrigerants**

Under no circumstances shall potential sources of ignition be used in the searching for or detection of refrigerant leaks. A halide torch (or any other detector using a naked flame) shall not be used.

- **Leak detection methods**

The following leak detection methods are deemed acceptable for systems containing flammable refrigerants. Electronic leak detectors shall be used to detect flammable refrigerants, but the sensitivity may not be adequate, or may need re-calibration. (Detection equipment shall be calibrated in a refrigerant-free area.) Ensure that the detector is not a potential source of ignition and is suitable for the refrigerant used. Leak detection equipment shall be set at a percentage of the LFL of the refrigerant and shall be calibrated to the refrigerant employed and the appropriate percentage of gas (25 %maximum) is confirmed. Leak detection fluids are suitable for use with most refrigerants but the use of detergents containing chlorine shall be avoided as the chlorine may react with the refrigerant and corrode the copper pipe-work. If a leak is suspected, all naked flames shall be removed/ extinguished. If a leakage of refrigerant is found which requires brazing, all of the refrigerant shall be recovered from the system, or isolated (by means of shut off valves) in a part of the system remote from the leak. Oxygen free nitrogen (OFN) shall then be purged through the system both before and during the brazing process.

- **Removal and evacuation**

When breaking into the refrigerant circuit to make repairs or for any other purpose conventional procedures shall be used. However, it is important that best practice is followed since flammability is a consideration. The following procedure shall be adhered to: Remove refrigerant; Purge the circuit with inert gas; Evacuate; Purge again with inert gas; Open the circuit by cutting or brazing. The refrigerant charge shall be recovered into the correct recovery cylinders. The system shall be flushed with OFN to render the unit safe. This process may need to be repeated several times. Compressed air or oxygen shall not be used for this task. Flushing shall be achieved by breaking the vacuum in the system with OFN and continuing to fill until the working pressure is achieved, then venting to atmosphere, and finally pulling down to a vacuum. This process shall be repeated until no refrigerant is within the system. When the final OFN charge is used, the system shall be vented down to atmospheric pressure to enable work to take place. This operation is absolutely vital if brazing operations on the pipe-work are to take place. Ensure that the outlet for the vacuum pump is not close to any ignition sources and there is ventilation available.

- **Charging procedures**

In addition to conventional charging procedures, the following requirements shall be followed. Ensure that contamination of different refrigerants does not occur when using charging equipment. Hoses or lines shall be as short as possible to minimise the amount of refrigerant contained in them.

Cylinders shall be kept upright.

Ensure that the refrigeration system is earthed prior to charging the system with refrigerant.

Label the system when charging is complete (if not already).

Extreme care shall be taken not to overfill the refrigeration system. Prior to recharging the system it shall be pressure tested with OFN. The system shall be leak tested on completion of charging but prior to commissioning. A follow up leak test shall be carried out prior to leaving the site.

- **Decommissioning**

Before carrying out this procedure, it is essential that the technician is completely familiar with the equipment and all its detail. It is recommended good practice that all refrigerants are recovered safely. Prior to the task being carried out, an oil and refrigerant sample shall be taken in case analysis is required prior to re-use of reclaimed refrigerant. It is essential that electrical power is available before the task is commenced.

a) Become familiar with the equipment and its operation.

b) Isolate system electrically.

c) Before attempting the procedure ensure that: Mechanical handling equipment is available, if required, for handling refrigerant cylinders; All personal protective equipment is available and being used correctly; The recovery process is supervised at all times by a competent person; Recovery equipment and cylinders conform to the appropriate standards.

d) Pump down refrigerant system, if possible.

e) If a vacuum is not possible, make a manifold so that refrigerant can be removed from various parts of the system.

f) Make sure that cylinder is situated on the scales before recovery takes place.

g) Start the recovery machine and operate in accordance with manufacturer's instructions.

h) Do not overfill cylinders. (No more than 80 % volume liquid charge).

i) Do not exceed the maximum working pressure of the cylinder, even temporarily.

j) When the cylinders have been filled correctly and the process completed, make sure that the cylinders and the equipment are removed from site promptly and all isolation valves on the equipment are closed off.

k) Recovered refrigerant shall not be charged into another refrigeration system unless it has been cleaned and checked.

- **Labelling**

Equipment shall be labelled stating that it has been de-commissioned and emptied of refrigerant. The label shall be dated and signed. Ensure that there are labels on the equipment stating the equipment contains flammable refrigerant.



- **Recovery**

When removing refrigerant from a system, either for servicing or decommissioning, it is recommended good practice that all refrigerants are removed safely. When transferring refrigerant into cylinders, ensure that only appropriate refrigerant recovery cylinders are employed. Ensure that the correct number of cylinders for holding the total system charge is available. All cylinders to be used are designated for the recovered refrigerant and labelled for that refrigerant (i.e. special cylinders for the recovery of refrigerant). Cylinders shall be complete with pressure relief valve and associated shut-off valves in good working order. Empty recovery cylinders are evacuated and, if possible, cooled before recovery occurs. The recovery equipment shall be in good working order with a set of instructions concerning the equipment that is at hand and shall be suitable for the recovery of flammable refrigerants. In addition, a set of calibrated weighing scales shall be available and in good working order. Hoses shall be complete with leak-free disconnect couplings and in good condition. Before using the recovery machine, check that it is in satisfactory working order, has been properly maintained and that any associated electrical components are sealed to prevent ignition in the event of a refrigerant release. Consult manufacturer if in doubt. The recovered refrigerant shall be returned to the refrigerant supplier in the correct recovery cylinder, and the relevant Waste Transfer Note arranged. Do not mix refrigerants in recovery units and especially not in cylinders. If compressors or compressor oils are to be removed, ensure that they have been evacuated to an acceptable level to make certain that flammable refrigerant does not remain within the lubricant. The evacuation process shall be carried out prior to returning the compressor to the suppliers. Only electric heating to the compressor body shall be employed to accelerate this process. When oil is drained from a system, it shall be carried out safely.



Exposed to the weather outdoors



Near water



If the power cable wires are frayed or cut



Where small children may be left unattended

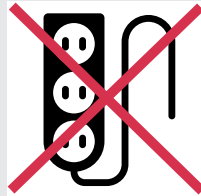

If an extension lead may become overloaded



Where the power cable may be damaged



On a slope or uneven surface



Where there is risk of fire or close to a naked flame



Where it may be damaged by chemicals



Where there is a risk of interference by foreign objects



This product is not made for DIY repair



If there is a risk of water falling on the unit

## Specification

<b>Model no.</b>	<b>DCPAC07C</b>
Colour	White
Power supply	220-240V~, 50Hz
Operating temperature	18-35°C
Thermostat range	18-32°C
Rated Input Power	830W
Cooling Capacity	2.05kW
Dehumidification Capacity	1.8L/hour
Noise Level Minimum (Lo)	62dB(A)
Noise Level Maximum (Hi)	64dB(A)
Air Volume (Hi/Lo)	225/200m <sup>3</sup> /h
Refrigerant	R290
Fan speeds	2
Modes	Sleep/Dry/Cool
Timer	24
Dimensions (w x d x h)	320 x 320 x 670mm
Min room size	13m <sup>2</sup>
Max room size	16m <sup>2</sup>
Weight net	22.6kg
Weight gross	25.6kg

- For greater precision, please always refer to the rating label placed on the product.

# Parts

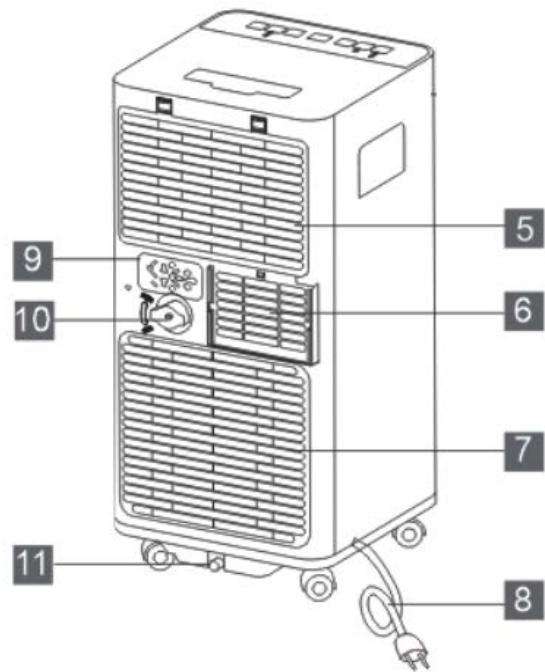
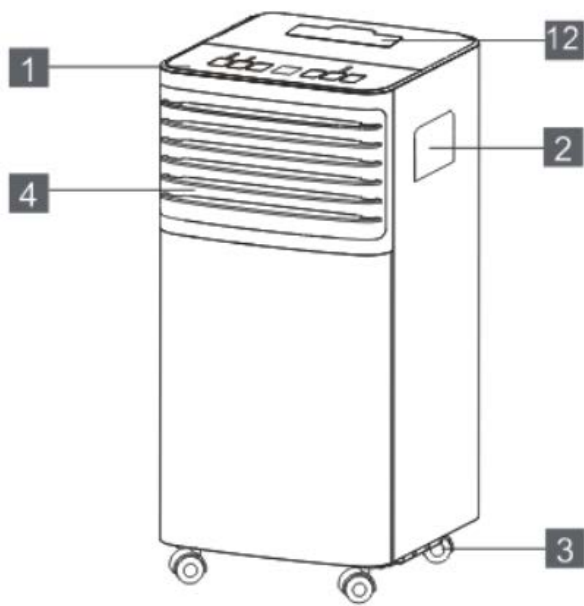

1. Control panel
2. Handles (both sides)
3. Castors
4. Louvres
5. Air intake grille
6. Air outlet
7. Air intake grille
8. Power cord
9. Plug/cord storage
10. Middle drain/plug
11. Lower drain/plug
12. Remote control storage

## 1 x Exhaust hose kit



## 1 x Window slider (with hole)

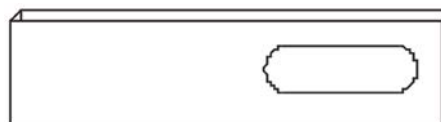

## 1 x Remote control



## 1 x Window slider (without hole)



## Control Panel

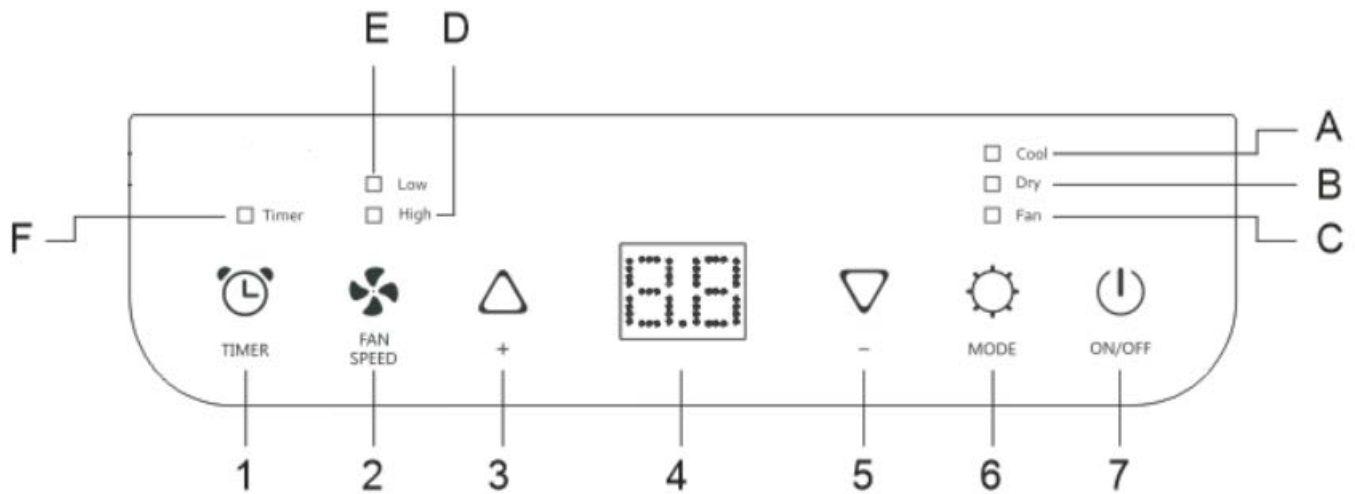

1. Timer button
2. Fan speed button
3. Increase button (+)
4. LED display screen
5. Decrease button (-)
6. Mode button
7. On/Off button

- A. Cool indicator
- B. Dry/dehumidify indicator
- C. Fan indicator
- D. High speed indicator
- E. Low speed indicator
- F. Timer indicator

## Remote Control

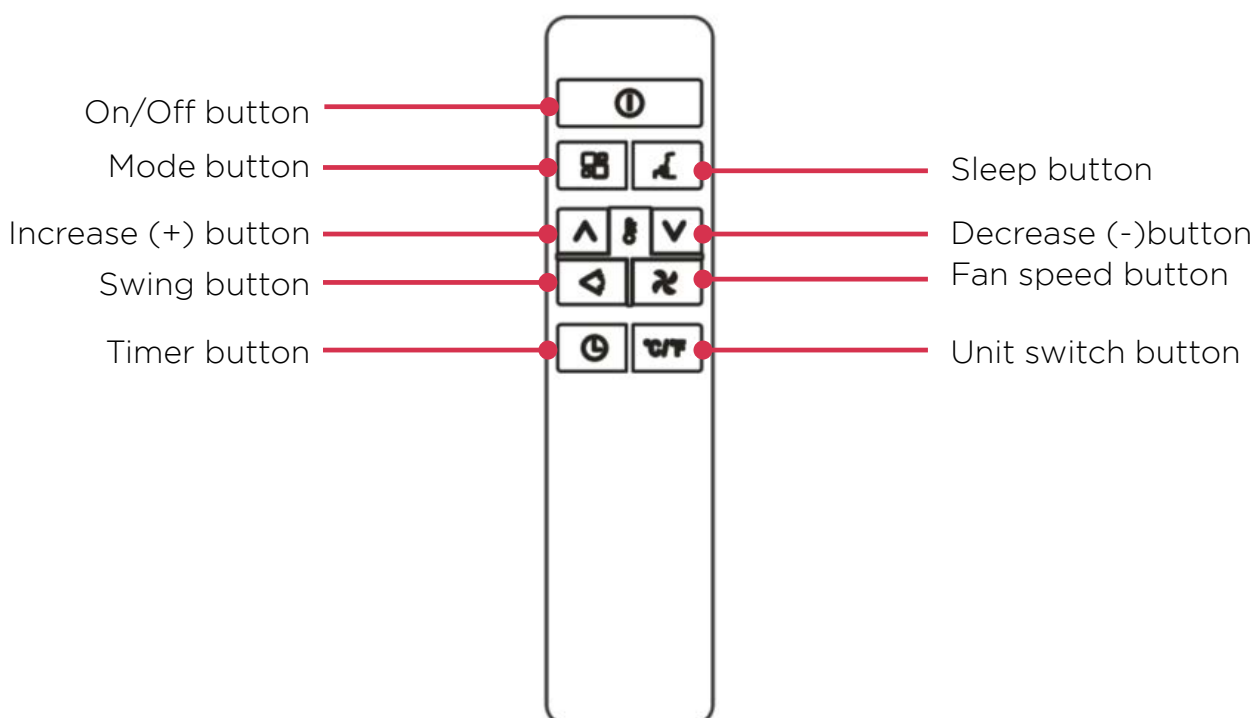

## PREPARATION

**NOTE:** All the illustrations in the manual are for explanatory purposes only. Your machine may be slightly different. The unit can be controlled by the control panel or with the remote control.

## EXHAUST HOSE INSTALLATION

The exhaust hose and adaptor must be installed or removed in accordance with the set MODE. For COOL & DRY MODE the exhaust hose must be installed. For FAN only mode the exhaust hose should be removed.

## EXHAUSTING HOT AIR

In COOL MODE the appliance must be placed close to a window or opening so that the warm exhaust air can be expelled outside.

## CHOOSING THE RIGHT LOCATION

Your installation location should meet the following requirements:

- Make sure that you install your unit on an even surface to minimize noise and vibration.
- The unit must be installed near a sufficient power outlet, and if using a continuous drainage method, then the plug areas should be accessible.
- The unit should be located at least 45cm from the nearest wall to ensure proper air conditioning. The horizontal louver blade should be at least 50cm away from obstacles.
- The exhaust hose can be extended, however it's best to keep it to the minimum length required. Ensure the hose doesn't have any sharp bends, sagging areas or kinks
- **DO NOT** cover the Intakes, outlets or remote control signal receptor of the unit, as this could cause damage to the unit.

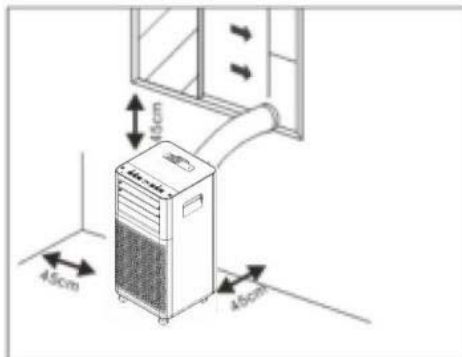
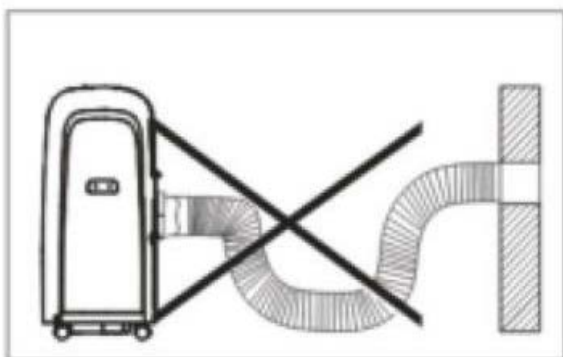

## EXHAUST HOSE INSTALLATION

1. Extend either side of the hose (Fig. 1)
2. Screw the hose to the inlet attachment (Fig. 2)
3. Screw the hose to the outlet attachment (Fig. 3)
4. Install the hose inlet into the unit (Fig. 4)
5. Affix the hose outlet into the window slider kit and seal. (Fig. 5 & 6).

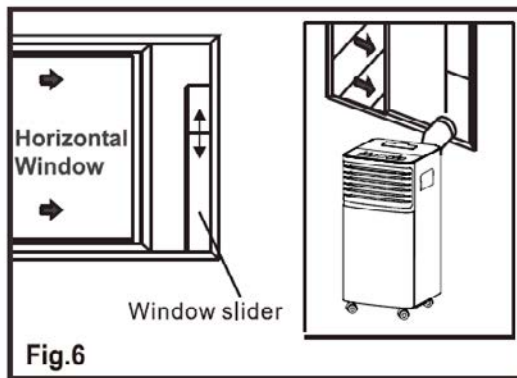
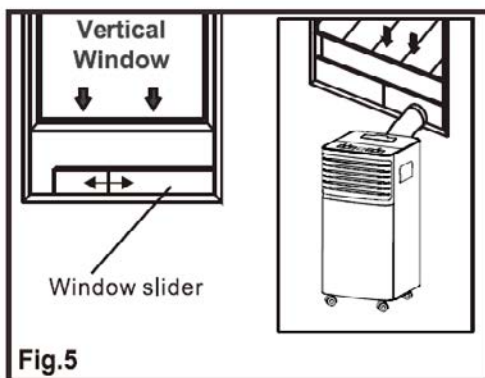
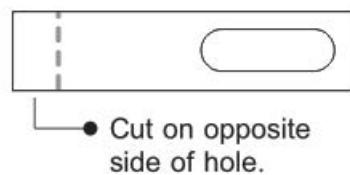
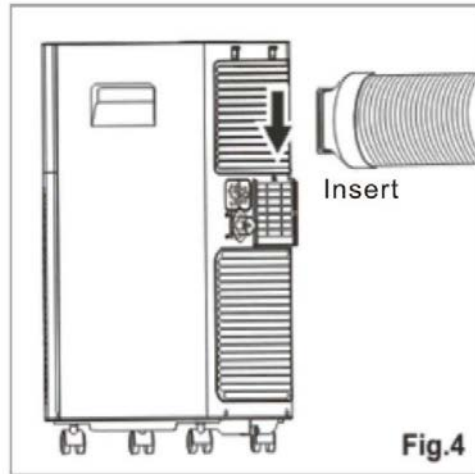
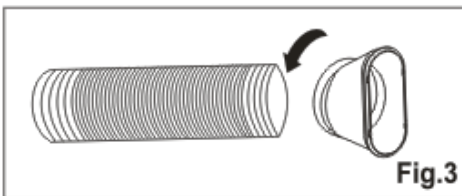
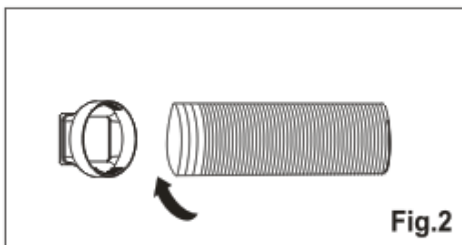
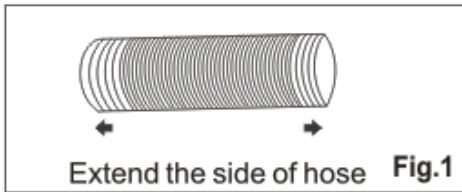

The window slider kit has been designed to fit most standard vertical and horizontal window applications, however it may be necessary for you to modify some aspects of the installation procedures for certain types of windows. The window slider kit can be fastened with screws (not supplied) if required.

**Note:** If the window opening is less than the minimum length of the window slider kit, cut the end without the hole, so it is short enough to fit in the window opening. Never cut out the hole in window slider kit.

## WINDOW KIT INSTALLATION

### Part Names

- A) Panel
- B) Panel with one hole
- D) Screws to lock window kit in place

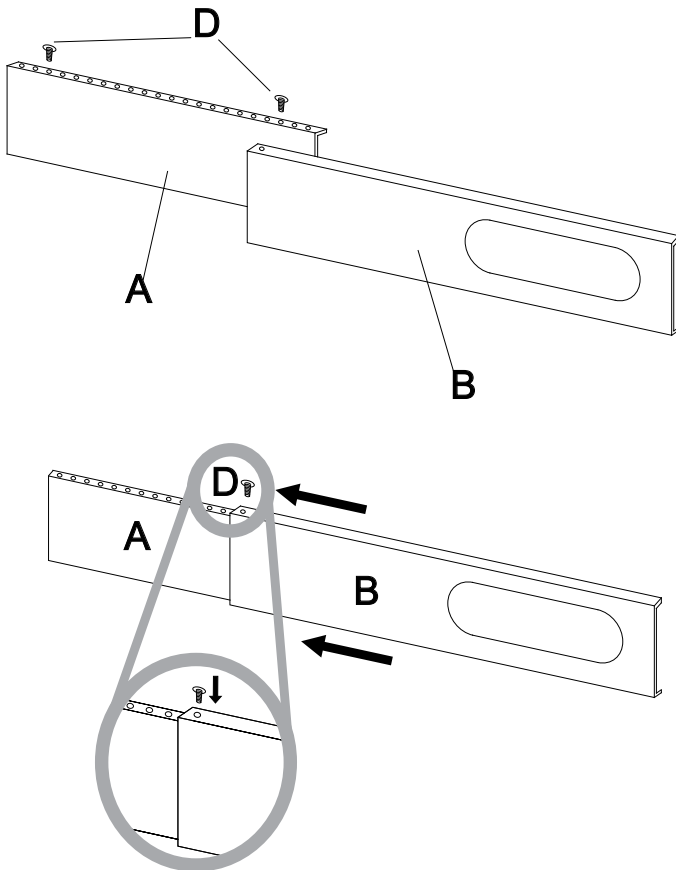

### Window Kit Assembly

- Slide Panel B into Panel A and size to window width. Windows sizes will vary. When sizing the window width, be sure that the window kit assembly is free from gaps from gaps and/or air pockets when taking measurements.
- Lock the screw into the holes that correspond with the width that your window requires to ensure that there are no gaps or air pockets in the window kit assembly after installation.



## **ON/OFF**

Press to turn the unit on/off.

## **LED display**

The LED displays indicates the timer setting or set temperature. When the set temperature or the timer is adjusted, the new setting is shown on the display. The LED display is also used to show error codes should a fault occur.

## **COOL MODE**

1. The exhaust hose needs to be installed for this mode.
2. To set this mode correctly, press the **MODE** button until the **COOL** indicator light illuminates on the control panel.
3. Set the target temperature between 18-32°C by pressing the increase **(+)** or decrease **(-)** buttons until the desired temperature is displayed on the LED display.
4. Select the fan speed by pressing the **FAN SPEED** button. This unit has 2 fan speeds to choose from. High speed will reach the set temperature as fast as possible and LOW, speed is ideal for low noise environments.

**TIP:** The most suitable temperature setting for a room during summer is 24°C.

## **FAN MODE**

1. When using the appliance in **FAN MODE** only, the air exhaust hose need to be removed.
2. Press the **MODE** button until the **FAN** indicator light illuminates on the control panel.
3. Select the fan speed by pressing the **FAN SPEED** button, there are 2 speeds as mentioned above.

## **DRY / DEHUMIDIFY**

1. To reduce room humidity (e.g..... damp rooms, or during rainy periods).
2. In **DRY MODE** the appliance should be prepared in the same way as **COOL MODE**, with the exhaust hose attached, so the moisture is taken from the room and expelled outside.
3. Press the **MODE** button until the **DRY** indicator light comes on. The LED display will show "**dh**" once activated.
4. The fan speed is selected automatically by the unit and defaults to LOW SPEED.

**NOTE:** Keep windows and doors closed for the best dehumidifying effect.

## **SWING FUNCTION**

This unit does not have an automatic-swing function. Please adjust the Horizontal louvres by hand until they are in the desired position.

**NOTE:** The unit must be **OFF** and disconnected from the power outlet when adjusting the louvres.

## SLEEP MODE

- The **SLEEP MODE** maintains the optimum room temperature without excessive fluctuations in either temperature or humidity and with quieter operation.
- Fan speed is always LOW, while room temperature and humidity vary gradually to ensure the most comfortable nights sleep.
- When operating in **COOL MODE**, the selected temperature will increase by 1°C per hour in a 2 hour period. This new temperature will be maintained for the next 6 hours. Then the appliance will turn off.
- The **SLEEP MODE** can be cancelled at any time during operation by pressing the **SLEEP, MODE**, or **FAN** buttons.
- Note: In **FAN** or **DRY** modes, **SLEEP** mode cannot be set.

### To set this function:

1. Select **COOL MODE** as described earlier.
2. Press the **SLEEP** button (remote control only).
3. When in **SLEEP MODE** the LED screen will dim and the unit will operate in LOW fan speed.

## SETTING THE TIMER

A timer can be set to automatically turn the appliance **ON** or automatically turn it **OFF**.

### To set the unit to automatically turn ON, follow the below instructions:

1. Turn the appliance **ON** and choose the modes you desire, for example COOLING MODE, 24°C and high fan speed, then turn **OFF** the appliance.
2. Press the **TIMER** button once, the LED screen will display 1-24 hours.
3. Continually press the **TIMER** button until the desired time is displayed. Wait 5 seconds for the **TIMER** to activate and for the indicator light to illuminate.
4. The unit is now programmed to turn **ON** after "X" amount of hours.

### To set the unit to automatically turn OFF, follow the below instructions:

1. While the appliance is running, press the **TIMER** button, the screen will display 1-24 hours.
2. Press the **TIMER** button until the desired time is displayed on the LED display. Wait 5 seconds for the **TIMER** to activate and for the indicator light to illuminate.
3. The unit is now programmed to turn **OFF** after "X" amount of hours.
4. To cancel any set timers press the **TIMER** button again to clear it. The indicator light will turn **OFF**.

## SWITCH UNITS

When the appliance is running you can switch between Celsius and Fahrenheit. Press the **UNIT SWITCH** button (remote control only) and the LED display will show the changed units.

# Error Codes

## ERROR CODES

### Lt - Low Temperature Error

The unit is fitted with a frost protection device to avoid excessive formation of ice. The unit will start automatically once the defrosting process is complete.

### PF - Probe Failure Error

If this is displayed, contact customer service or your local authorised service centre.

### Ft - Full Tank Error

Empty the water following the instructions in the "Water Drainage" Section.

## Water Drainage

### WATER DRAINAGE METHOD

When there is excess water condensation inside the unit, the unit will stop running and show and '**Ft**' (Full Tank) Error Code. This indicates that the water needs to be drained using the following procedure:

#### Manual Drainage:

1. Unplug the unit from the power supply.
2. Place a bucket/pan (not supplied) under the lower drain plug. See diagram 24.
3. Remove the lower drain plug.
4. The water will begin to drain out and collect in the bucket/pan.
5. After the water is drained, replace the lower drain plug.

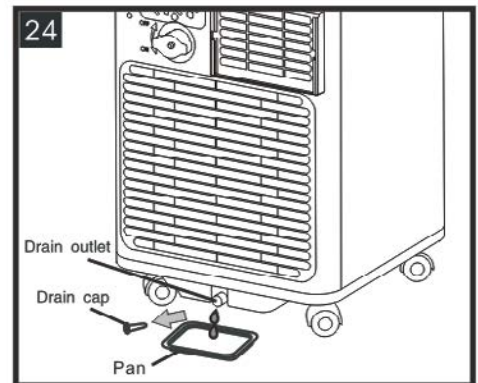

#### Continuous Drainage:

1. Unplug the unit from the power supply.
2. Remove the lower drain plug. While doing this some residual water may spill out, so please have a bucket or pan ready to collect any water.
3. Connect a drain hose (1/2" or 12.7mm, not supplied). See diagram 25.
4. The water can be continuously drained through the hose into a floor drain or bucket.

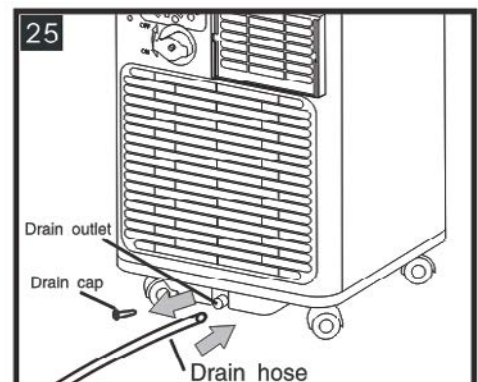

# Water Drainage

## WATER DRAINAGE NOTE

Please be sure that the drain hose is not higher than that of the drain outlet, or the water may not drain properly. (See diagram 26 & 27)

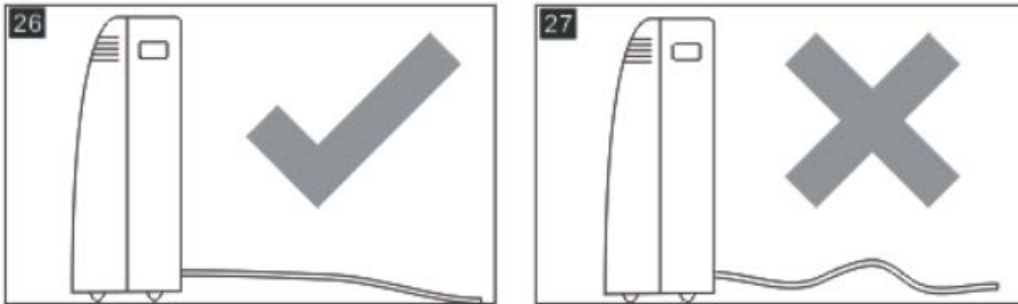

## MIDDLE DRAINAGE

When the unit is running in Dry/Dehumidify mode, you can choose middle drainage as a way of continuous drainage.

1. Unplug the unit from the power supply.
2. Remove the drain plug (see diagram A). While doing this some residual water may spill out, so please have a bucket or pan ready to collect any water.
3. Connect the drain hose (1/2" or 12.7mm, not supplied) (see diagram B)
4. The water can be continuously drained through the hose into a floor drain or bucket.

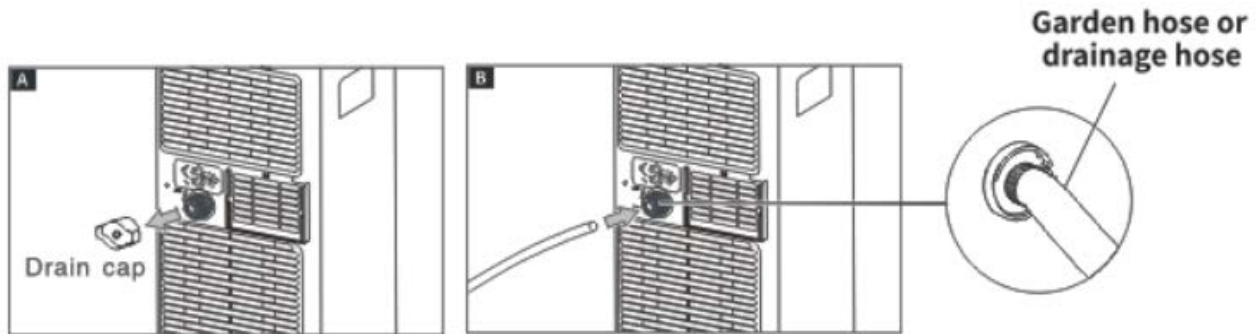

## MIDDLE DRAINAGE NOTE

Please be sure that the drain hose is not higher than that of the middle drain outlet, or the water may not drain properly. Please see following diagram.

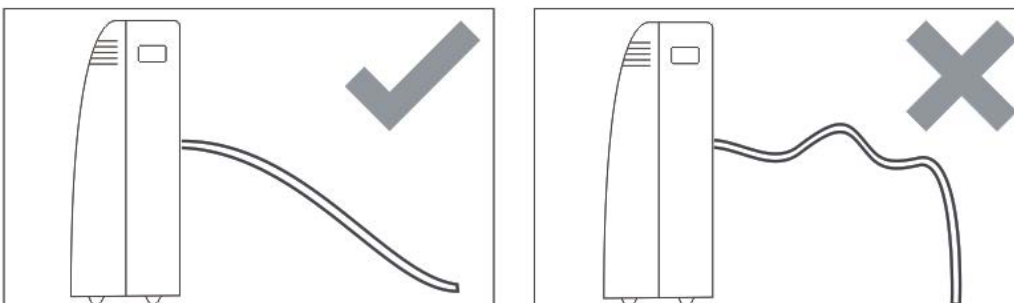

# Remote Control

## Using the Remote Control

1. Open the battery cover of the remote control, and insert 2 x AAA batteries.
2. Please point to the receiver and be within 7m when using the remote control.
3. If the battery voltage is low, please open the battery cover as per the diagram and replace with a new batteries (2 x AAA). Then replace the battery cover.

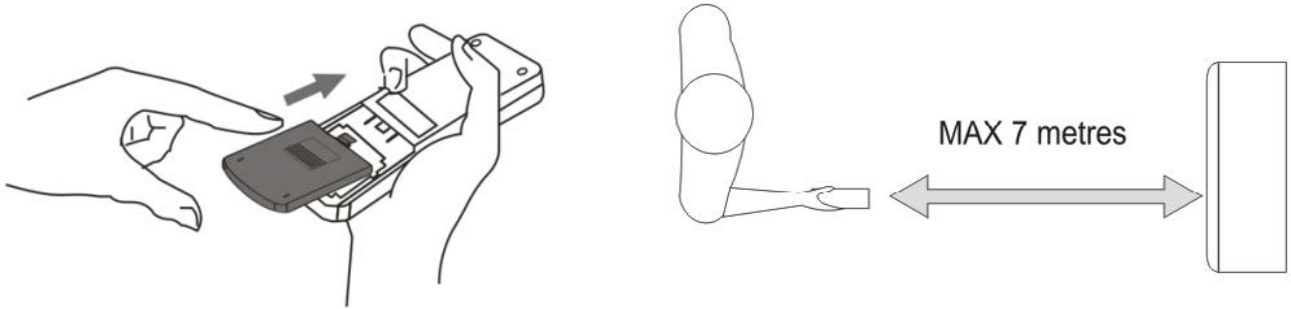

### NOTE:

- If the remote control unit is replaced or disposed of, the batteries must be removed and discarded in accordance with current legislation as they are harmful to the environment.
- Do not mix old and new batteries. Do not mix alkaline, standard (carbon-zinc) or rechargeable (nickel-cadmium) batteries.
- Do not dispose of batteries in fire. Batteries may explode or leak.
- If the remote control is not be used for a certain length of time, remove the batteries.

## SAFETY PRECAUTIONS

- Always unplug the unit before cleaning or servicing.
- **DO NOT** use flammable liquids or chemicals to clean the unit.
- **DO NOT** wash the unit under running water. Doing so causes electrical danger.
- **DO NOT** operate the machine if the power supply was damaged during cleaning. A damaged power cord must be replaced with a new cord from the manufacturer.

## AIR FILTER

**CAUTION:** Never operate the unit without a filter in place.

- Be sure to clean the air filter every week of operation for optimal performance.
- The water collection tray should be drained immediately after "P1" error occurs, and before storage to prevent mold.
- In households with animals, you will have to periodically wipe down the grill to prevent blocked airflow due to animal hair.

Following the below diagram, remove the filter from the back of the unit. Use a vacuum cleaner to remove dust from the filter. If further cleaning is required, the filter can be washed in lukewarm water (never hotter than 40 degrees). Ensure it is left to dry completely before reinstalling.

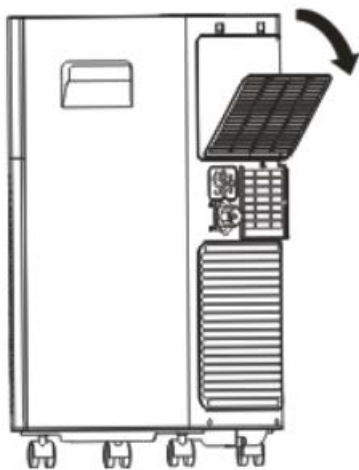

## Outside Cabinet

1. Remove any dust build up with a soft brush.
2. Wipe the surface of the unit with a soft damp cloth. Mild detergent can be used for any stubborn marks.

**Do not** use abrasive sponges, scouring pads, or a stiff brush to clean the unit.

## IMPORTANT

The control panel and other parts must not come into contact with water or any other liquids.

## Maintenance

### Storage

If not using the unit for an extended period of time. After cleaning please:

- Turn the unit **OFF**, unplug and take care of the mains lead & plug.
- Drain any water from the unit according to the instructions in the following sections.
- Run the appliance on **FAN MODE** for 12 hours in a warm room to dry out and prevent mould.
- Clean the air filter as described on the previous page.
- Remove the batteries from the remote control.
- Cover the unit and store it upright in a location where it will not receive direct sunlight. NB- Prolonged exposure to direct sunlight will discolour the outer casing.

If the unit fails to operate efficiently, is broken or other problems arise, unplug and do not operate. Ask for advice by calling your local after sales service agent or the Customer Care Centre on 1300 556 816 (AU) / 0800 666 2824 (NZ).

## Warranty

Please refer to the warranty card in the box for warranty information. For any troubleshooting advice, please contact the relative Customer Care Centre below.

### **Glen Dimplex Australia Pty Ltd**

1340 Ferntree Gully Road,  
Scoresby 3179, Victoria  
Australia  
Ph: 1300 556 816

### **Glen Dimplex New Zealand Ltd**

38 Harris Road, East Tamaki,  
Auckland 2013  
New Zealand  
Ph: 0800 666 2824

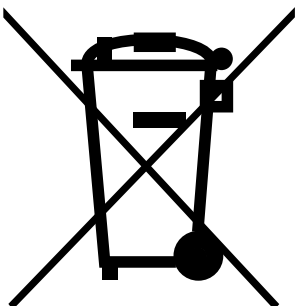

*Recycling: Do not dispose of electrical appliances as unsorted municipal waste. Use separate collection facilities. Contact your local government for information regarding the collection systems available. If electrical appliances are disposed of in landfills or dumps, hazardous substances can leak into the ground water, polluting the food chain and damaging health and well-being.*



**Customer Care:** 1300 556 816  
customer.care@glendimplex.com.au  
www.dimplex.com.au

Supplied by Glen Dimplex Australia  
1340 Ferntree Gully Road, Scoresby, Victoria, 3179

---

© Glen Dimplex Australia. All rights reserved. Material contained in this publication may not be reproduced in whole or in part, without prior permission in writing of Glen Dimplex Australia.