

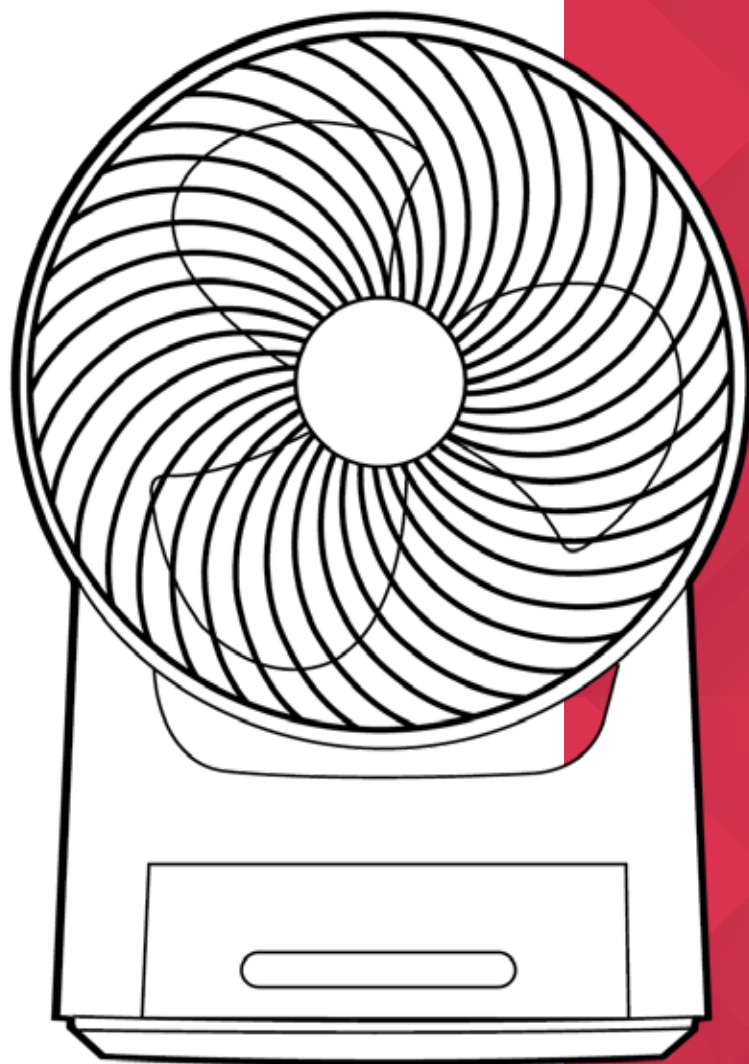

INSTRUCTION MANUAL



Air Circulator

Model: DCACE20

For domestic household use only.



IMPORTANT

THESE INSTRUCTIONS SHOULD BE READ CAREFULLY AND RETAINED FOR FUTURE REFERENCE. **Note also the information presented on the appliance**

CAUTION: FAILURE TO FOLLOW THESE INSTRUCTIONS MAY CAUSE INJURY AND/OR DAMAGE AND MAY INVALIDATE YOUR WARRANTY

Please read the operating instructions carefully before using your dehumidifier for the first time and keep them in a safe place.

WARNING - This appliance must not be used in a bathroom.

WARNING - Do not use this appliance in the immediate surroundings of a bath, a shower or a swimming pool.

- Never immerse the appliance in water or other liquids.
- Do not place on soft, unstable or non-horizontal/angled surfaces.
- Never operate the appliance if a cable or connector has been damaged, after appliance malfunction or if the appliance was dropped or is otherwise damaged.
- If the mains lead is damaged it must only be replaced by the manufacturers service agent or a similarly qualified person in order to avoid a hazard.
- Please ask a professional service agent to repair the product. Improper repair may cause danger to users.
- Disconnect the appliance from mains power whenever it is not in use, before relocating it, and before cleaning.
- Operate the appliance only at the voltage specified on the rating label.
- Only connect the unit to a properly installed and easily accessible socket so that you can quickly disconnect the plug if necessary.
- Do not connect this product to the mains using an extension lead.
- This air circulator is only intended for **INDOOR RESIDENTIAL** applications. This air circulator should not be used for commercial or industrial or leisure applications or in small enclosed spaces.
- Never use the mains lead as a carrying strap or pulling lead.
- To avoid a fire or electrocution hazard, **NEVER** put the cord near heat registers, radiator, stoves or heaters.
- **DO NOT** cover cord with carpeting, throw rugs, runners, or similar coverings.
- **DO NOT** route cord under furniture or appliances. Take care to position the cord away from traffic areas and where it will not be a tripping hazard.
- **DO NOT** use the unit near windows or where water collects. Rain and water collection may lead to a risk of fire or electric shock.
- **DO NOT COVER.**
- Only operate this appliance with a minimum of 50cm clearance all around i.e. away from walls, furniture and overhanging objects such as curtains or a shelf.
- This appliance is not intended for use by persons (including children) with reduced physical, sensory or mental capabilities, or lack of experience and knowledge, unless they have been given supervision or instruction concerning use of the appliance by a person responsible for their safety.

- Children should be supervised to ensure they do not play with the appliance.
- **WARNING:** To avoid danger of suffocation please remove all packaging materials particularly plastic and EPS and keep these away from vulnerable people, children and babies.
- **NEVER** drop or insert any object or fingers into any openings.
- Do not use the appliance in locations where paint, petrol or other flammable liquids are used or stored.
- If the supply cord is damaged, it must be replaced by the manufacturer, its service agent or similarly qualified persons in order to avoid a hazard.
- Do not use bug sprays or other flammable cleansers/vapour sprays on or around the unit.
- Always switch off the unit and take the plug out of the socket:
 - If you are not using the unit
 - Before you clean or carry out maintenance on the unit
 - If a fault occurs
 - In the event of an electrical storm.
- Avoid electromagnetic interference. Keep the unit at least 1 metre away from electrical appliances such as televisions & radios.



Exposed to the weather outdoors



Near water



If the power cable wires are frayed or cut



Where small children may be left unattended

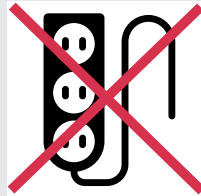

If an extension lead may become overloaded



Where the power cable may be damaged



On a slope or uneven surface



Where there is risk of fire or close to a naked flame



Where it may be damaged by chemicals



Where there is a risk of interference by foreign objects



This product is not made for DIY repair



If there is a risk of water falling on the unit

Specification

Model no.	DCACE20
Power supply	220-240V~, 50Hz
Rated power	45W
Speed settings	3
Modes	3
Timer	0-8 hours
Air movement	20m
Wind speed	7m/s
Vertical oscillation	90 degrees
Horizontal oscillation	360 degrees
Noise level	35dB(A) [low speed]
Weight (net)	1.9kg
Dimensions (w x d x h)	225 x 215 x 320mm

- For greater precision, please always refer to the rating label placed on the product.

How It Works

In contrast to a traditional fan which brings only cooling benefits when directly facing you; an air circulator works for any season, keeping the air in motion and making the entire room more comfortable to be in.

Most fans simply lack the aerodynamics to keep the air in the room in motion. As opposed to blowing air directly in contact with it, our WhirlTech air circulators create a 360° oscillating draught in the form of an invisible jet stream.

This jet stream helps maintain a constant room temperature by ridding the room of cold and warm spots. It also clears stuffy atmospheres by circulating stale air with fresh air from an open window.

Air circulators are the safe, all-year-round temperature regulation solution you've been looking for.

Where To Position

During Summer, pointing the air circulator towards a wall halfway between the floor and the ceiling, as well as using the highest setting, will set up a high speed air circulation pattern.

This will cool down the room in an efficient manner. Pointing towards your air conditioner will help distribute the cool air faster, saving time and energy; essentially Turbo boosting your A/C.

During Winter, the use of a heater alone produces warm air that rises naturally to the ceiling.

By pointing the air circulator upwards, and utilising the lowest speed setting, the hot air will circulate with the cooler air near the floor, resulting in a more even room temperature.

Parts

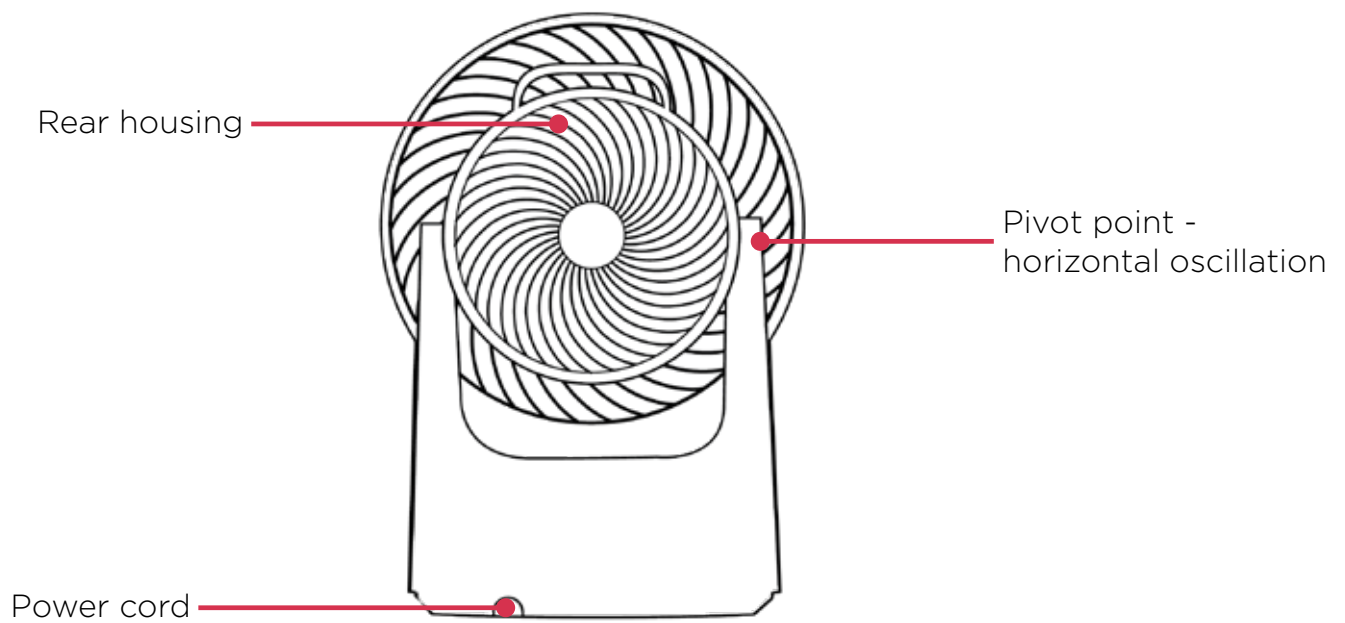
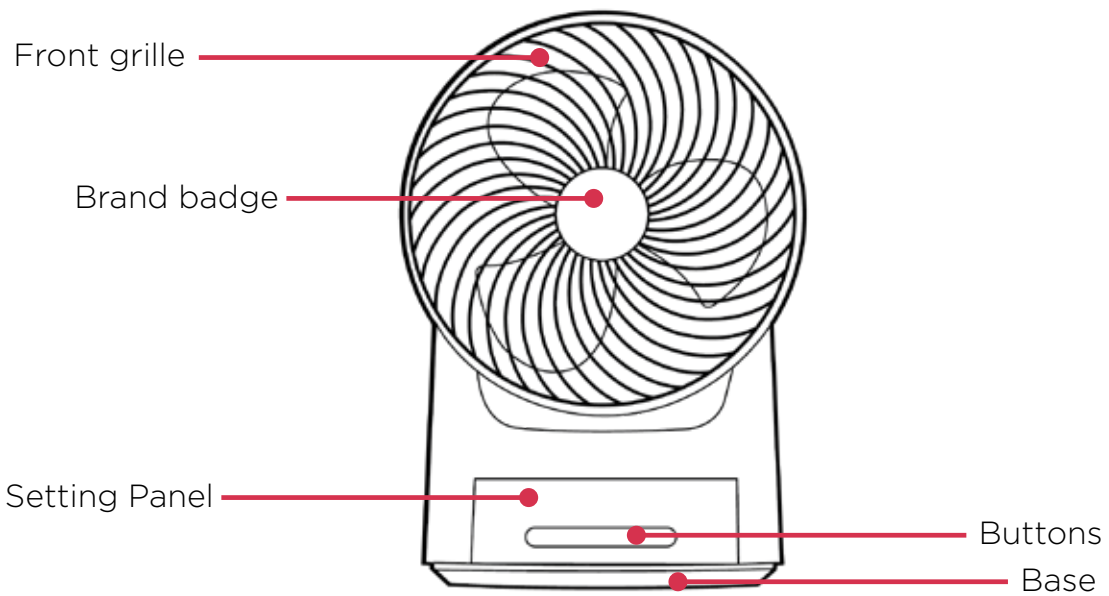

Control Panel

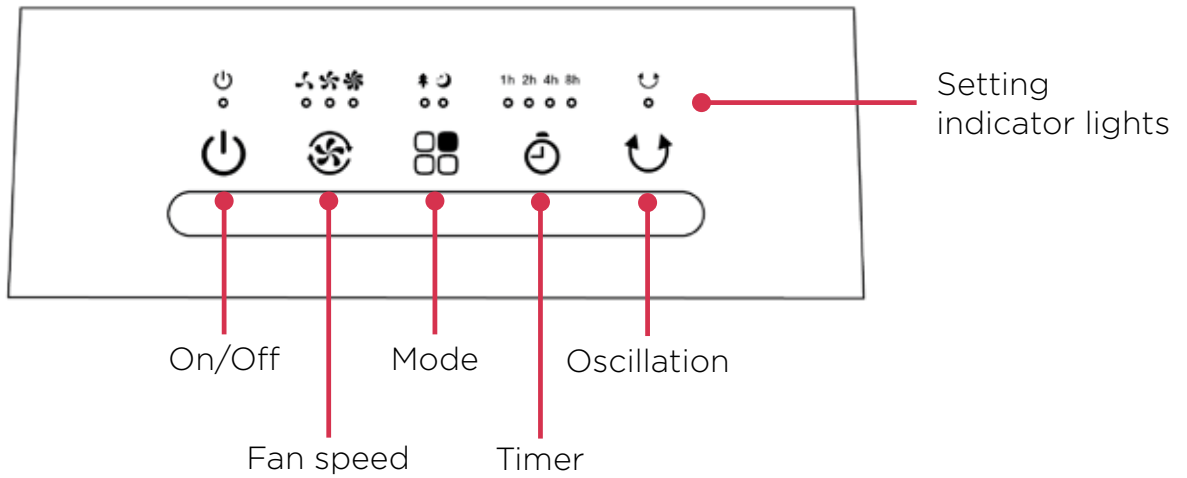

Settings

Off

This button is used to switch the unit on and off. By simply pressing the button, you can turn the unit on or off. Once turned on, default mode is Normal Mode & Low Speed.

Fan Speed

This button is used to select the desired fan speed – Low, Med, or High. The fan speed indicator light will illuminate indicating what speed has been selected. Press once for low speed, press twice for medium speed, press three times for high speed. Pressing again in high speed, will return to low speed.

Mode

This button is used to switch between pre-set operating modes. By pressing the mode button, you can select between NORMAL, NATURAL or SLEEP. The unit automatically starts in NORMAL mode.

Normal: Operates normally with the selected wind speed – Low, Med, High.

Natural: The fan speeds automatically shift through High, Med, Low speed to imitate a natural wind speed rhythm.

Sleep: The fan will run using the natural wind mode pattern and automatically lowers the set wind speed in 30 minute intervals depending on the speed setting and then run continuously at low speed.

Sleep on high: high wind speed for half an hour, then medium speed for half an hour, then low speed continuously

Sleep on medium: medium speed for half an hour, then low speed continuously

Sleep on low: low speed continuously

Settings

Timer

This air circulator comes with an 8 hour timer that allows you to pre-set the unit to switch off automatically, in intervals of 1, 2, 4 or 8 hours. To operate, simply select the number of hours ahead you wish the unit to switch off and the respective indicator lights will illuminate. If you'd like the unit to run continuously, ensure no timer indicator lights are illuminated.

Oscillation

Press the oscillation button to activate 360° Horizontal oscillation. Press again to deactivate.

90° Vertical Oscillation/Tilt

Tilt the fan head to achieve up to 90° angled oscillation. Ensure the fan is OFF when adjusting the fan head position.

Operation

Steps

1. Remove the unit from its packaging
2. Plug the unit into a power outlet, a 'beep beep' will sound and the unit will be in standby mode.
3. Press the "On/Off" button to turn the unit On.
4. Press the "Fan Speed" button to change the fan speed (low, med, high).
5. The unit defaults in "Normal" mode. Press the mode button to change to Natural or Sleep Mode.
6. The unit will operate initially on a continual basis. If a set period of operation is required, please follow "TIMER" instructions on page 5.
7. To activate 360° oscillation, press the oscillation button. To turn off oscillation, press again.
8. To switch the unit off at any time, press the "On/Off" button.

Cleaning

Over time, dust can accumulate on the rear grille cover and fan blades, which can affect the fans performance. It is recommended to clean the fan at least once a month.

1. Turn the unit OFF and disconnect the appliance from the power supply.
2. Remove any dust build up with a soft brush.
3. Wipe the surface of the unit with a soft damp cloth. Mild detergent can be used for any stubborn marks.

NOTE: The fan cover cannot be removed.

IMPORTANT

The control panel and other parts must not come into contact with water or any other liquids.

Storage

If not using the unit for an extended period of time. After cleaning please:

- Turn the unit off, unplug and take care of the mains lead & plug.
- Cover the unit and store it upright in a location where it will not receive direct sunlight. NB- Prolonged exposure to direct sunlight will discolour the enclosure.

Maintenance

If the unit fails to operate efficiently, is broken or other problems arise, unplug and do not operate. Ask for advice by calling your local after sales service agent or the Customer Care Centre on 1300 556 816 (AU) / 0800 666 2824 (NZ).

Warranty

Please refer to the warranty card in the box for warranty information. For any troubleshooting advice, please contact the relative Customer Care Centre below.

Glen Dimplex Australia Pty Ltd

1340 Ferntree Gully Road,
Scoresby 3179, Victoria
Australia
Ph: 1300 556 816

Glen Dimplex New Zealand Ltd

38 Harris Road, East Tamaki,
Auckland 2013
New Zealand
Ph: 0800 666 2824

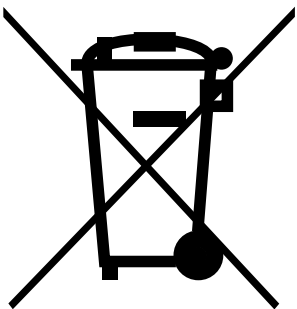

Recycling: Do not dispose of electrical appliances as unsorted municipal waste. Use separate collection facilities. Contact your local government for information regarding the collection systems available. If electrical appliances are disposed of in landfills or dumps, hazardous substances can leak into the ground water, polluting the food chain and damaging health and well-being.



Customer Care: 1300 556 816
customer.care@glendimplex.com.au
www.dimplex.com.au

Supplied by Glen Dimplex Australia
1340 Ferntree Gully Road, Scoresby, Victoria, 3179

© Glen Dimplex Australia. All rights reserved. Material contained in this publication may not be reproduced in whole or in part, without prior permission in writing of Glen Dimplex Australia.